

A
SIZE

PROJECTIONS

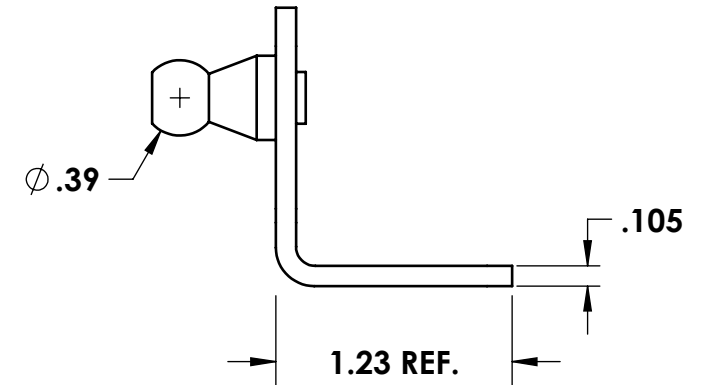
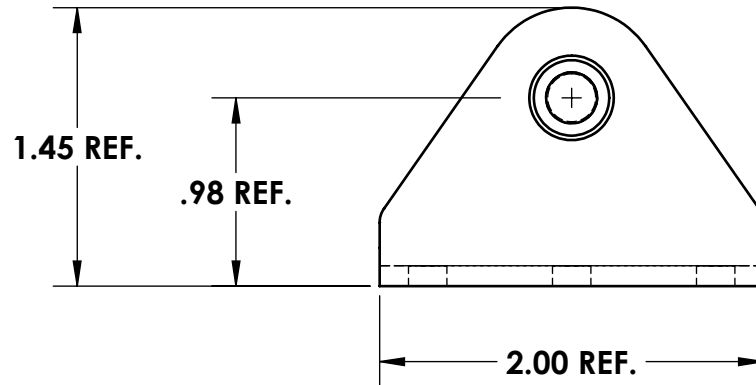
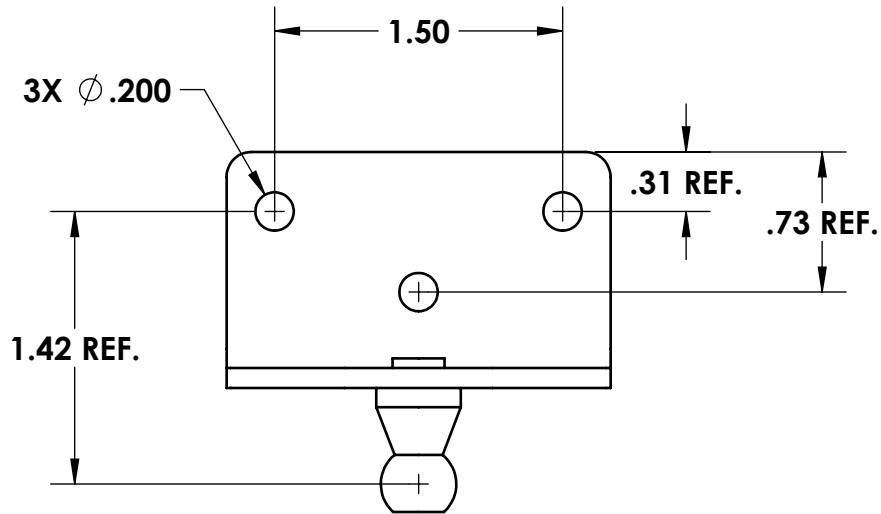
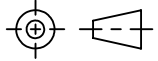

TOLERANCES UNLESS OTHERWISE SPECIFIED:

PLACES	INCHES	NOTES:
.XX	± .030	ACCEPTABLE BURR ± 10% OF MATERIAL THICKNESS
.XXX	± .015	ALL TOLERANCES ARE NON-CUMULATIVE
.XXXX	± .005	ALL DIMENSIONS APPLY TO PART BEFORE ANY FINISH IS APPLIED
ANGLE	± 3°	

NOTES:

- FINISH: 105- BARREL ZINC AND CLEAR TRIVALENT CHROMATE

REV.	DESCRIPTION	DATE	APPD	DWG #:	SCALE	CODE IDENT. #
I	CONVERTED	09/20/2022	JG	BR205-02	1:1	03007
H	CHANGED FINISH	02/03/2012	JG		DATE	
G	CHANGED MATERIAL THICKNESS	11/21/1997	CD	MATERIAL: PS	FINISH: SEE NOTE	
F	REDRAWN, VARIOUS CHANGES	06/27/1996	CD	DR. BY: RAG	CK. BY: CD	
REVISIONS				FAX: 1-631-737-2933		 GUDEN INDUSTRIAL HARDWARE MADE EASY 99 RAYNOR AVE. RONKONKOMA, N.Y. 11779 1-800-3-HINGES
				EMAIL: info@guden.com		
				WEB: www.guden.com		