

A
SIZE

PROJECTIONS

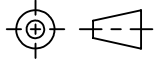

TOLERANCES UNLESS OTHERWISE SPECIFIED:

PLACES	INCHES	NOTES:
.XX	± .030	ACCEPTABLE BURR ± 10% OF MATERIAL THICKNESS
.XXX	± .015	ALL TOLERANCES ARE NON-CUMULATIVE
.XXXX	± .005	ALL DIMENSIONS APPLY TO PART BEFORE ANY FINISH IS APPLIED
ANGLE	± 3°	

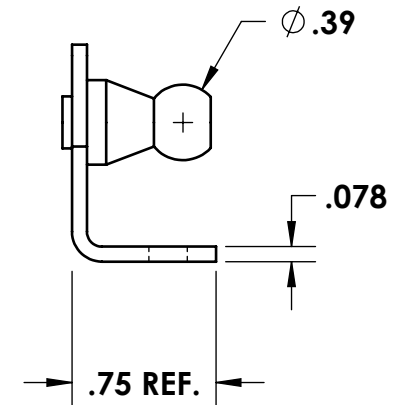
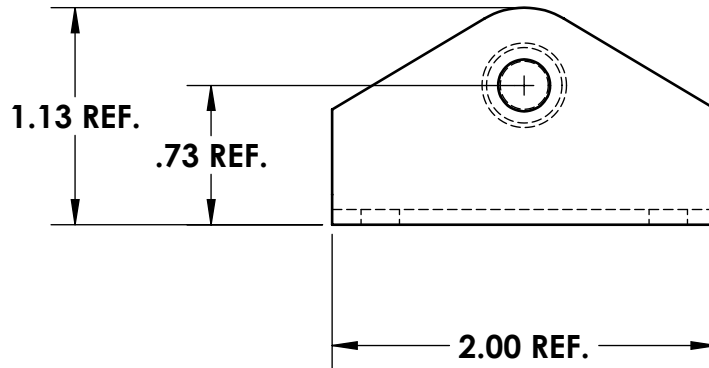
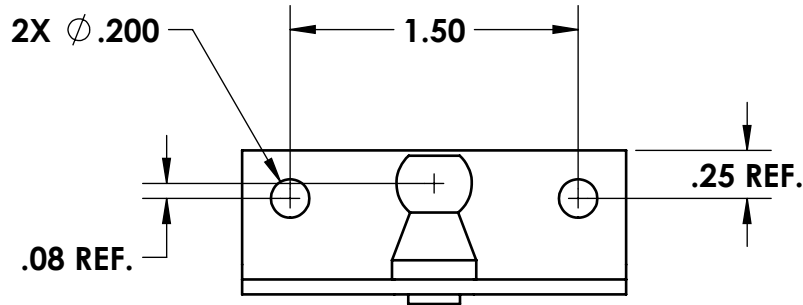

NOTES:
1. FINISH: 47- BLACK POWDER COAT

				DWG #:		SCALE	1:1	CODE IDENT. #
				BR204R-02B		DATE	10/03/1996	03007
B	CONVERTED	09/22/2022	JG	MATERIAL:	FINISH:	 99 RAYNOR AVE. RONKONKOMA, N.Y. 11779 1-800-3-HINGES		
A	CHANGED FINISH	09/29/2004	CD	PS	SEE NOTE			
REV.	DESCRIPTION	DATE	APPD	DR. BY: RAG	CK. BY: CD			
REVISIONS				FAX: 1-631-737-2933				
				EMAIL: info@guden.com				
				WEB: www.guden.com				