

A
SIZE

PROJECTIONS

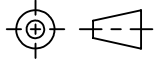

TOLERANCES UNLESS OTHERWISE SPECIFIED:

| PLACES | INCHES | NOTES: |
|--------|--------|---|
| .XX | ± .030 | ACCEPTABLE BURR ± 10% OF MATERIAL THICKNESS |
| .XXX | ± .015 | ALL TOLERANCES ARE NON-CUMULATIVE |
| .XXXX | ± .005 | ALL DIMENSIONS APPLY TO PART BEFORE ANY FINISH IS APPLIED |
| ANGLE | ± 3° | |

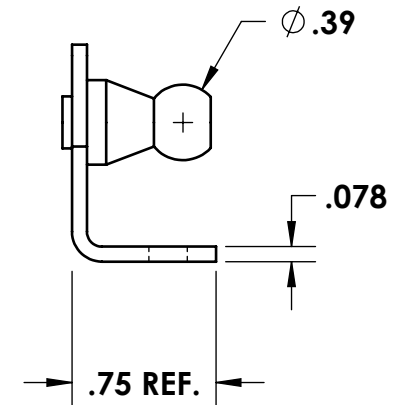
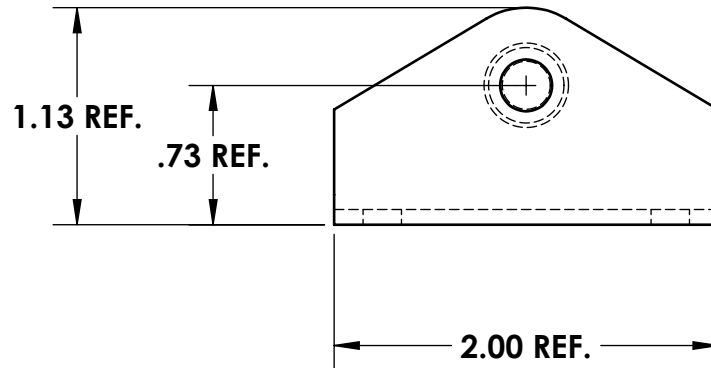
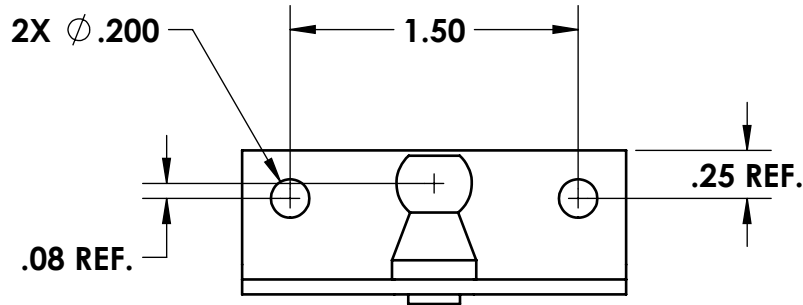

NOTES:
1. FINISH: 105- BARREL ZINC AND CLEAR TRIVALENT CHROMATE

| | | | | |
|--|------------|---|------------|---------------|
| DWG #: | | SCALE | 1:1 | CODE IDENT. # |
| BR204R-02 | | DATE | 11/13/1996 | 03007 |
| MATERIAL: | FINISH: | GUDEN INDUSTRIAL HARDWARE MADE EASY 99 RAYNOR AVE. RONKONKOMA, N.Y. 11779 1-800-3-HINGES | | |
| PS | SEE NOTE | | | |
| DR. BY: RAG | CK. BY: CD | | | |
| FAX: 1-631-737-2933 EMAIL: info@guden.com WEB: www.guden.com | | | | |

| REV. | DESCRIPTION | DATE | APPD |
|-----------|----------------|------------|------|
| A | CHANGED FINISH | 09/22/2022 | JG |
| REVISIONS | | | |