

A
SIZE

PROJECTIONS

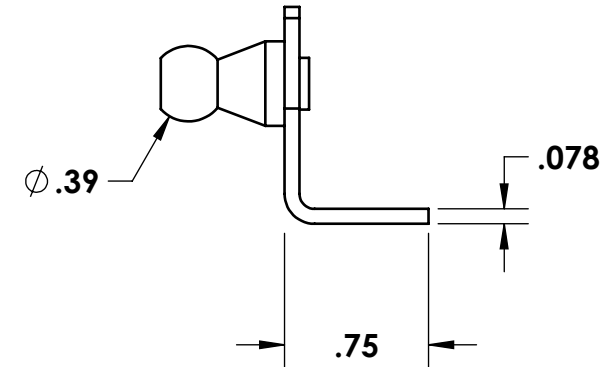
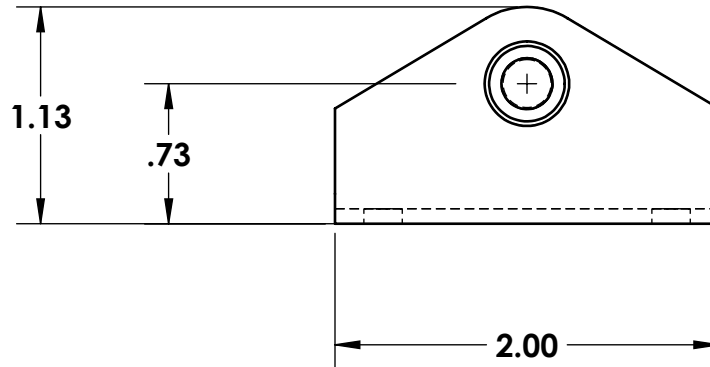
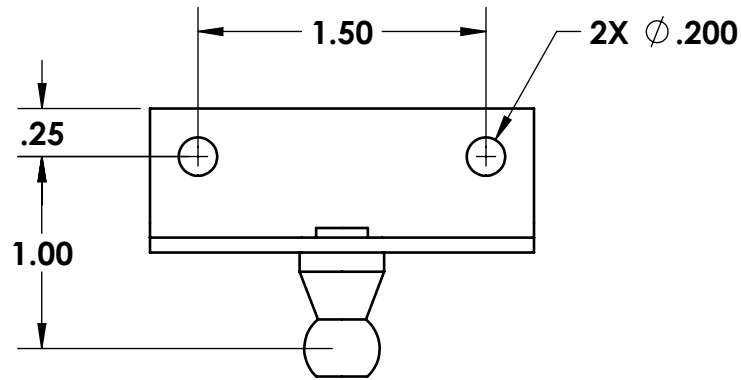
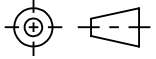

TOLERANCES UNLESS OTHERWISE SPECIFIED:

PLACES	INCHES	NOTES:
.XX	± .030	ACCEPTABLE BURR ± 10% OF MATERIAL THICKNESS
.XXX	± .015	ALL TOLERANCES ARE NON-CUMULATIVE
.XXXX	± .005	ALL DIMENSIONS APPLY TO PART BEFORE ANY FINISH IS APPLIED
ANGLE	± 3°	

NOTES:

- FINISH: 00- NO FINISH

REV. DESCRIPTION DATE APPD				DWG #:		SCALE	1:1	CODE IDENT. #
				BR204-32		DATE	07/18/1996	03007
C	CONVERTED, FINISH	06/09/2017	JG	MATERIAL:	FINISH:	GUDEN INDUSTRIAL HARDWARE MADE EASY 99 RAYNOR AVE. RONKONKOMA, N.Y. 11779 1-800-3-HINGES		
B	ALL STS, POLISH	02/05/2004	CD	304-STs	SEE NOTE			
A	ADDED FINISH	06/20/2000	CD	DR. BY: RAG	CK. BY: CD			
REV.	DESCRIPTION	DATE	APPD	FAX: 1-631-737-2933				
REVISIONS				EMAIL: info@guden.com				
				WEB: www.guden.com				