

A
SIZE

PROJECTIONS

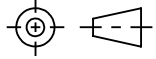

TOLERANCES UNLESS OTHERWISE SPECIFIED:

PLACES	INCHES	NOTES:
.XX	± .030	ACCEPTABLE BURR ± 10% OF MATERIAL THICKNESS
.XXX	± .015	ALL TOLERANCES ARE NON-CUMULATIVE
.XXXX	± .005	ALL DIMENSIONS APPLY TO PART BEFORE ANY FINISH IS APPLIED
ANGLE	± 3°	

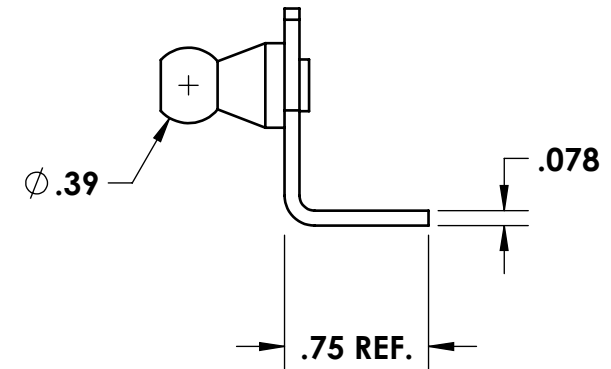
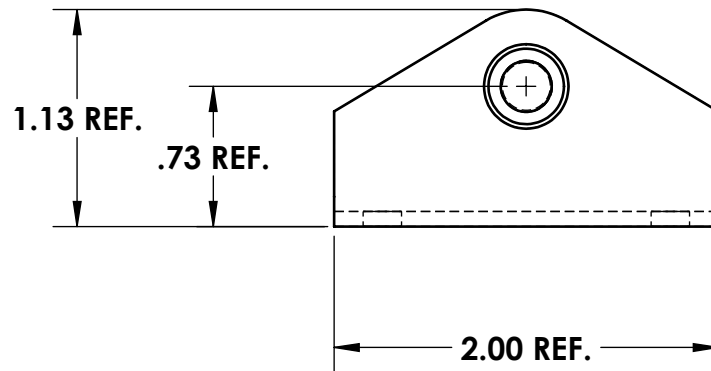
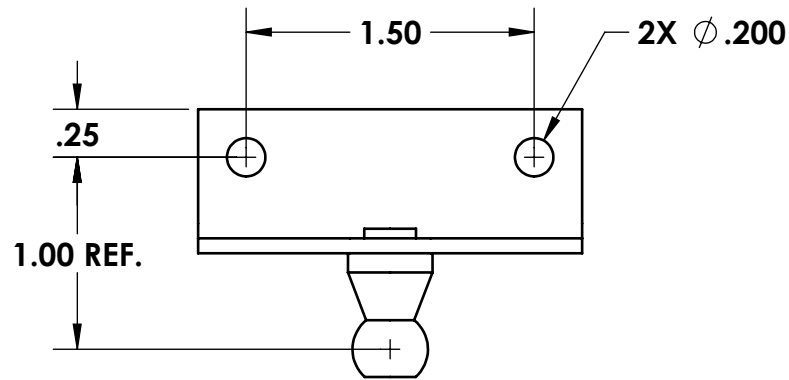
**NOTES:**

1. FINISH: 105- BARREL ZINC AND CLEAR TRIVALENT CHROMATE

REV.	DESCRIPTION	DATE	APPD
G	CONVERTED, CHANGED FINISH	10/11/2022	JG
F	REDRAWN, VARIOUS CHANGES	06/27/1996	CD
E	VARIOUS CHANGES	12/27/1992	AG
D	VARIOUS CHANGES	12/10/1992	AG
REVISIONS			

DWG #:		SCALE	1:1	CODE IDENT. #
BR204-02		DATE	06/27/1996	03007
MATERIAL:	PS	FINISH:	SEE NOTE	
DR. BY:	RAG	CK. BY:	CD	
FAX: 1-631-737-2933				
EMAIL: info@guden.com				
WEB: www.guden.com				

GUDEN	
INDUSTRIAL HARDWARE MADE EASY	
99 RAYNOR AVE.	
RONKONKOMA, N.Y. 11779	
1-800-3-HINGES	