

A
SIZE

PROJECTIONS

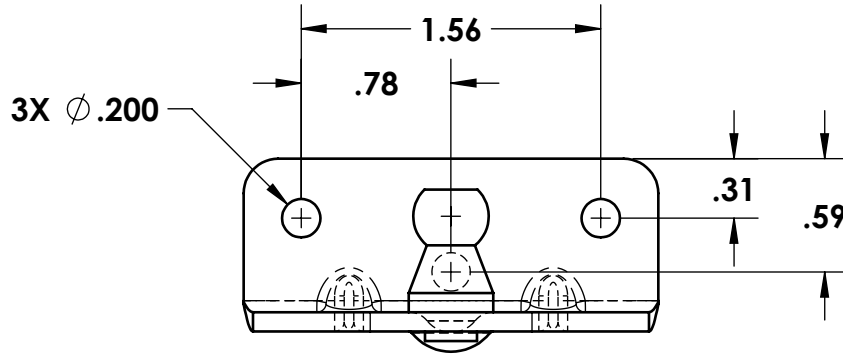
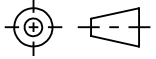

TOLERANCES UNLESS OTHERWISE SPECIFIED:

PLACES	INCHES	NOTES:
.XX	± .030	ACCEPTABLE BURR ± 10% OF MATERIAL THICKNESS
.XXX	± .015	ALL TOLERANCES ARE NON-CUMULATIVE
.XXXX	± .005	ALL DIMENSIONS APPLY TO PART BEFORE ANY FINISH IS APPLIED
ANGLE	± 3°	

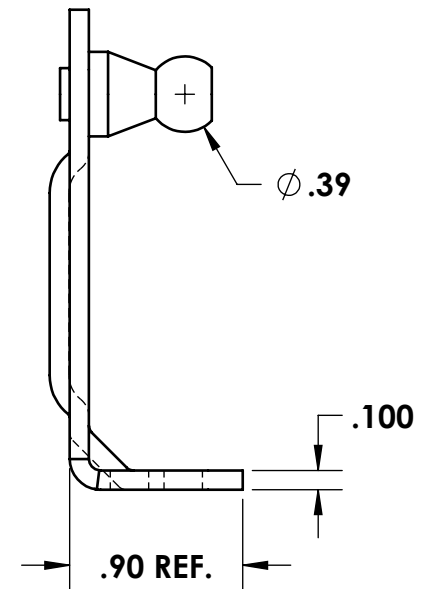
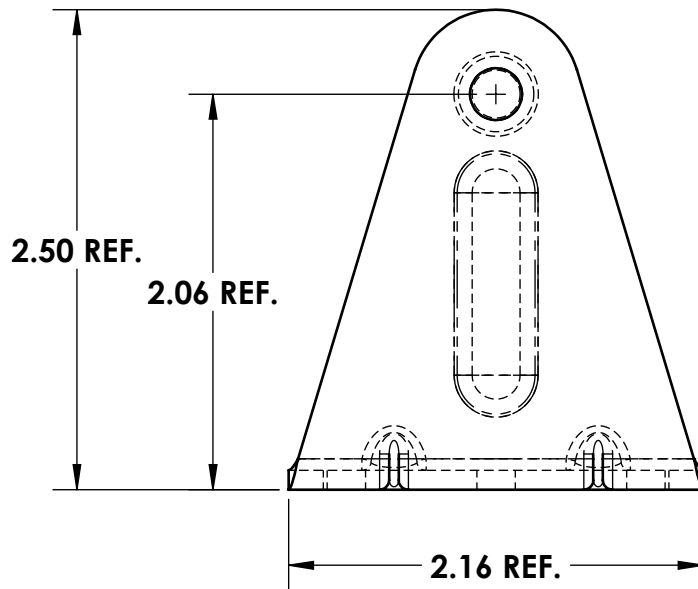

NOTES:
1. FINISH: 105- BARREL ZINC AND CLEAR TRIVALENT CHROMATE

DWG #:		SCALE	1:1	CODE IDENT. #
BR201R-02		DATE	06/27/1996	03007
MATERIAL:	FINISH:	 99 RAYNOR AVE. RONKONKOMA, N.Y. 11779 1-800-3-HINGES		
PS	SEE NOTE			
DR. BY: RAG	CK. BY: CD			
FAX: 1-631-737-2933				
EMAIL: info@guden.com				
WEB: www.guden.com				

REV.	DESCRIPTION	DATE	APPD
A	FINISH	12/27/2023	JG
REVISIONS			