

A
SIZE

PROJECTIONS

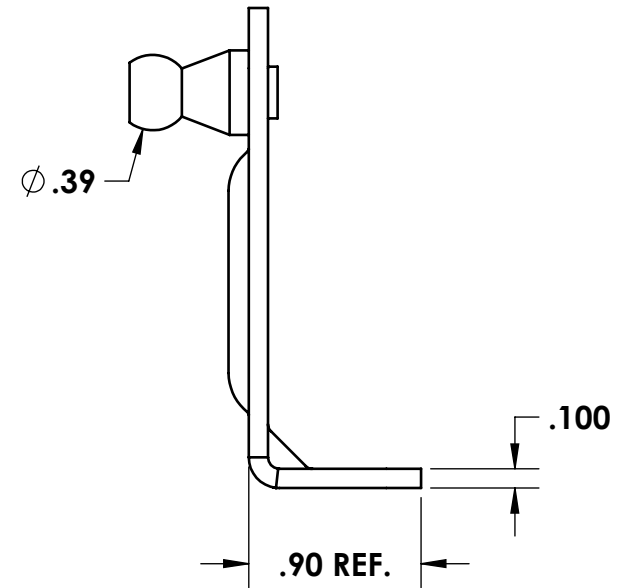
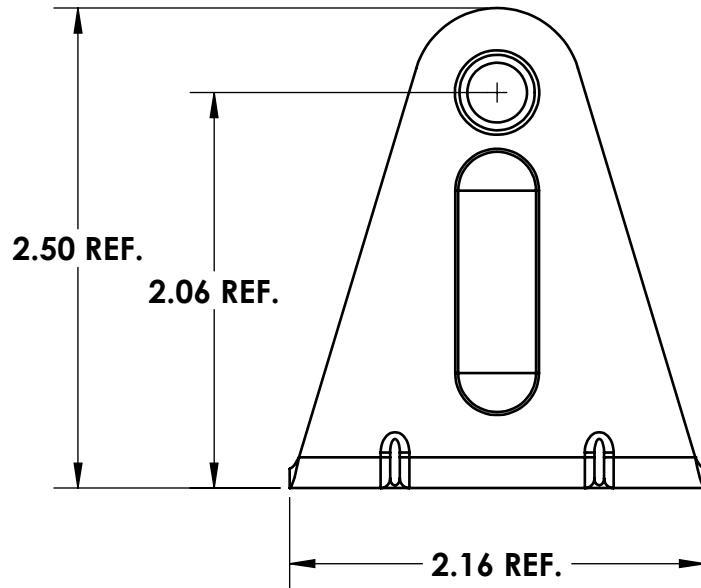
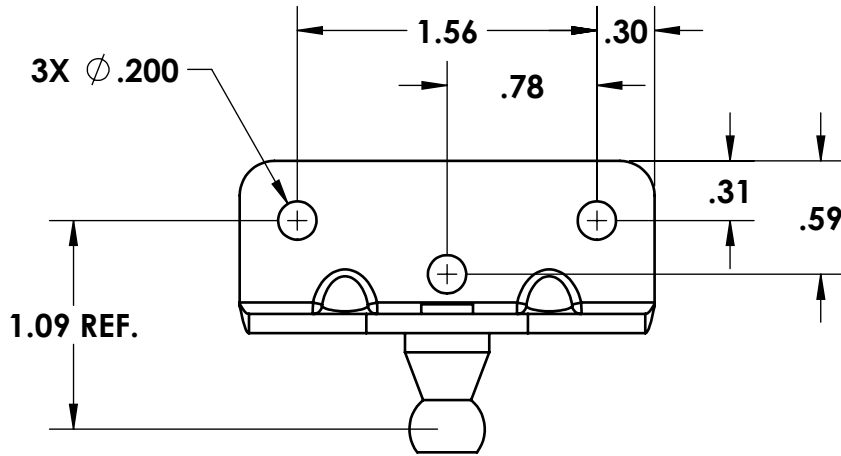
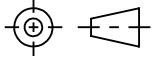

TOLERANCES UNLESS OTHERWISE SPECIFIED:

PLACES	INCHES	NOTES:
.XX	± .030	ACCEPTABLE BURR ± 10% OF MATERIAL THICKNESS
.XXX	± .015	ALL TOLERANCES ARE NON-CUMULATIVE
.XXXX	± .005	ALL DIMENSIONS APPLY TO PART BEFORE ANY FINISH IS APPLIED
ANGLE	± 3°	

NOTES:

1. FINISH: 00- NO FINISH

REV.	DESCRIPTION	DATE	APPD
E	CONVERTED	06/09/2017	JG
D	CHANGED HOLE LOCATIONS	10/05/2007	CD
C	ALL STS, POLISH	02/05/2004	CD

REVISIONS

DWG #:

BR201-32

MATERIAL:
304-STSS

FINISH:
SEE NOTE

DR. BY: RAG

CK. BY: CD

FAX: 1-631-737-2933
EMAIL: info@guden.com
WEB: www.guden.com

SCALE

1:1

CODE IDENT. #

DATE

07/18/1996

03007

GUDEN

INDUSTRIAL HARDWARE MADE EASY

99 RAYNOR AVE.

RONKONKOMA, N.Y. 11779

1-800-3-HINGES