

A
SIZE

PROJECTIONS



TOLERANCES UNLESS OTHERWISE SPECIFIED:

PLACES	INCHES	NOTES:
.XX	± .030	ACCEPTABLE BURR ± 10% OF MATERIAL THICKNESS
.XXX	± .015	ALL TOLERANCES ARE NON-CUMULATIVE
.XXXX	± .005	ALL DIMENSIONS APPLY TO PART BEFORE ANY FINISH IS APPLIED
ANGLE	± 3°	

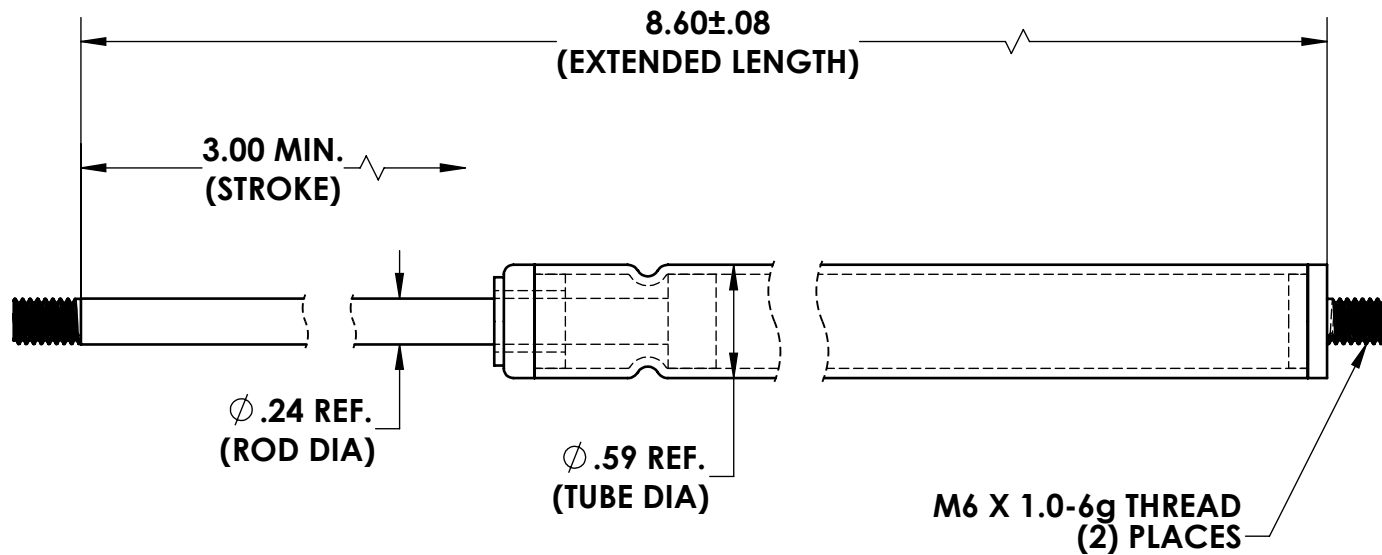

NOTES:

1. FINISH: 51A BLACK PAINT (TUBE) AND BLACK NITRIDE (ROD)
2. PART MARK WITH GUDEN P/N AND DATE CODE
3. MEDIUM DAMPING (ORIFICE PLATE D) IN COMPRESSION

DWG #:

GNC51-D

SCALE

1:1

CODE IDENT. #

DATE

01/05/2016

03007

MATERIAL:
PSFINISH:
SEE NOTE

DR. BY: RAG

CK. BY: JPG

FAX: 1-631-737-2933

EMAIL: info@guden.com

WEB: www.guden.com

GUDEN

INDUSTRIAL HARDWARE MADE EASY

99 RAYNOR AVE.

RONKONKOMA, N.Y. 11779

1-800-3-HINGES

REV.	DESCRIPTION	DATE	APPD
A	CONVERTED	04/13/2017	JG
REVISIONS			