

A
SIZE

PROJECTIONS



TOLERANCES UNLESS OTHERWISE SPECIFIED:

PLACES	INCH
.XX	± .030
.XXX	± .015
.XXXX	± .005
ANGLE	3°

NOTE:
ACCEPTABLE BURR ± 10% OF MATERIAL THICKNESS
ALL TOLERANCES ARE NON-CUMULATIVE
ALL DIMENSIONS APPLY TO PART BEFORE ANY FINISH IS APPLIED

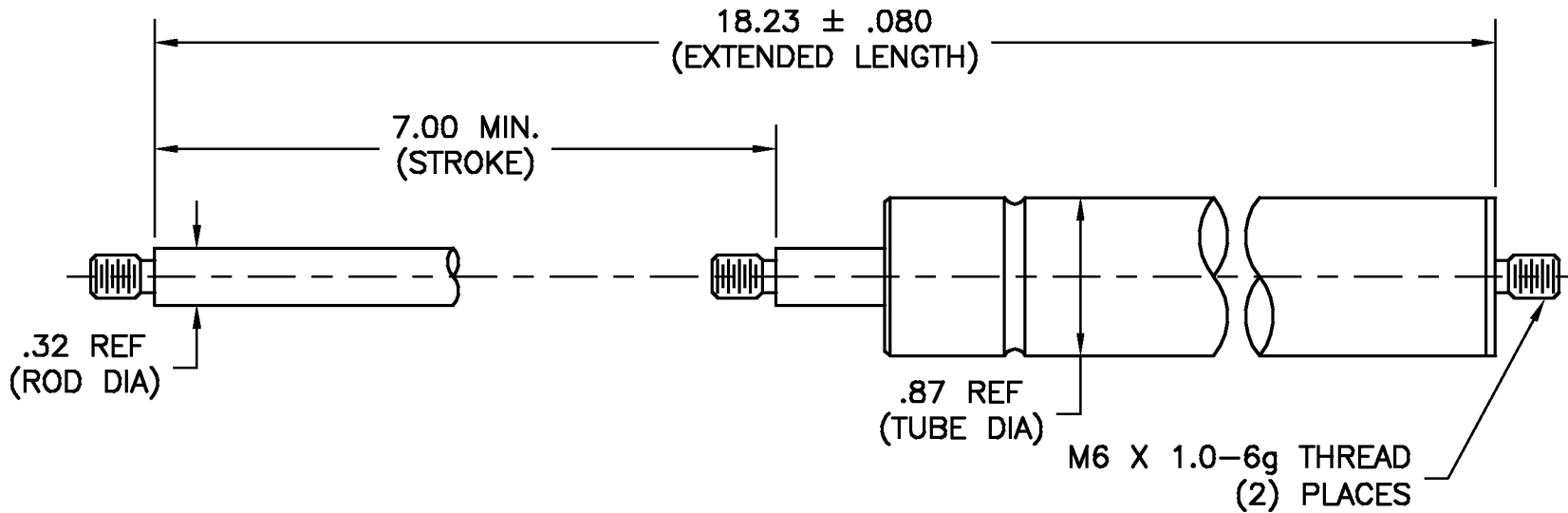

NOTES:

1. FINISH: 61- BLACK PAINT (TUBE) AND CHROME (ROD)
2. PART MARK WITH GUDEN P/N AND DATE CODE
3. MEDIUM DAMPING (ORIFICE PLATE E) IN COMPRESSION

LTR	DESCRIPTION	DATE	APPD
D	VARIOUS CHANGES	10/19/15	JG
C	VARIOUS CHANGES	10/16/14	JG
B	CORRECTED ROD AND TUBE	03/14/08	CD
A	CHANGED NOTE 4	06/06/06	CD
REVISION			

DWG		SCALE	N/A	CODE IDENT. #
GDC63-E		DATE	09/28/04	03007
MATERIAL	FINISH			
PS	SEE NOTE			
DR. BY RAG	CK. BY CD	99 RAYNOR AVE. RONKONKOMA, N.Y. 11779 1-800-3-HINGES		
FAX: 1-631-737-2933				
EMAIL: info@guden.com				
WEB: www.guden.com				