

**A**  
SIZE

PROJECTIONS



TOLERANCES UNLESS OTHERWISE SPECIFIED:

PLACES		INCH
.XX	±	.030
.XXX	±	.015
.XXXX	±	.005
ANGLE	±	3°

NOTE:

ACCEPTABLE BURR ± 10% OF MATERIAL THICKNESS  
ALL TOLERANCES ARE NON-CUMULATIVE  
ALL DIMENSIONS APPLY TO PART BEFORE ANY FINISH IS APPLIED

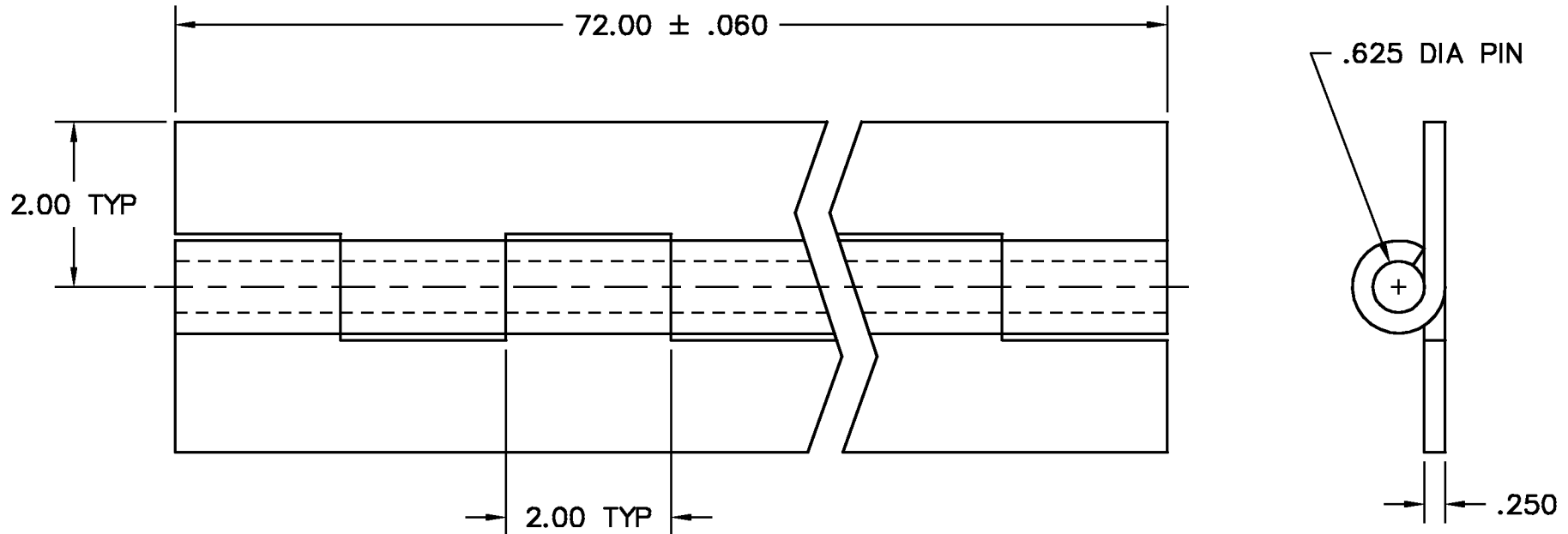

NOTES:

1. FINISH: 00- NO FINISH

DWG  
PS12110811-72

SCALE	1:2	CODE IDENT. #
DATE	04/27/15	03007

MATERIAL PS FINISH SEE NOTE

DR. BY RAG CK. BY JG

**GUDEN**  
DELIVERING HARDWARE EXCELLENCE

FAX: 1-631-737-2933  
EMAIL: info@guden.com  
WEB: www.guden.com

99 RAYNOR AVE.  
RONKONKOMA, N.Y. 11779  
1-800-3-HINGES

LTR	DESCRIPTION	DATE	APPD
	REVISION		