

A  
SIZE

PROJECTIONS



TOLERANCES UNLESS OTHERWISE SPECIFIED:

PLACES	INCH
.XX	± .030
.XXX	± .015
.XXXX	± .005
ANGLE	3°

NOTE:  
ACCEPTABLE BURR ± 10% OF MATERIAL THICKNESS  
ALL TOLERANCES ARE NON-CUMULATIVE  
ALL DIMENSIONS APPLY TO PART BEFORE ANY FINISH IS APPLIED

.125 DIA PIN  
SPUN BOTH ENDS

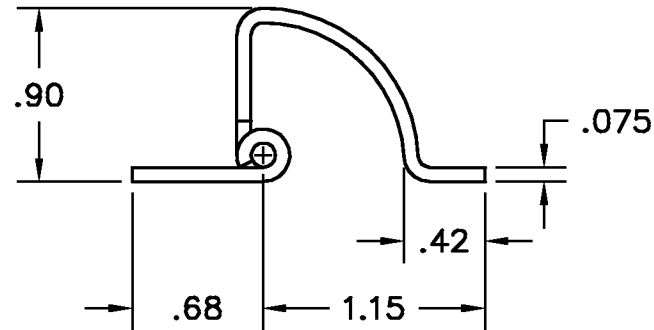
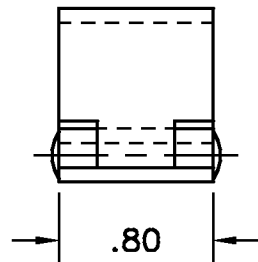
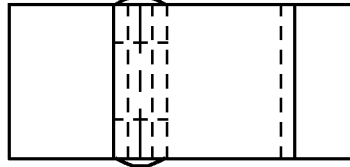

NOTES:  
1. FINISH: 00- NO FINISH

DWG		SCALE	1:1	CODE IDENT. #
NHSS9290		DATE	01/05/99	03007
MATERIAL	FINISH			
STS	SEE NOTE			
DR. BY RAG	CK. BY CD	<p>99 RAYNOR AVE. RONKONKOMA, N.Y. 11779 1-800-3-HINGES</p>		
FAX: 1-631-737-2933	EMAIL: info@guden.com			
WEB: www.guden.com				

A	REVISION	DATE	APPD
	REDRAWN	01/05/99	CD
LTR	DESCRIPTION	DATE	APPD
	REVISION		