

**A**  
SIZE

PROJECTIONS

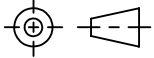

TOLERANCES UNLESS OTHERWISE SPECIFIED:

PLACES	INCHES	NOTES:
.XX	± .030	ACCEPTABLE BURR ± 10% OF MATERIAL THICKNESS
.XXX	± .015	ALL TOLERANCES ARE NON-CUMULATIVE
.XXXX	± .005	ALL DIMENSIONS APPLY TO PART BEFORE ANY FINISH IS APPLIED
ANGLE	± 3°	

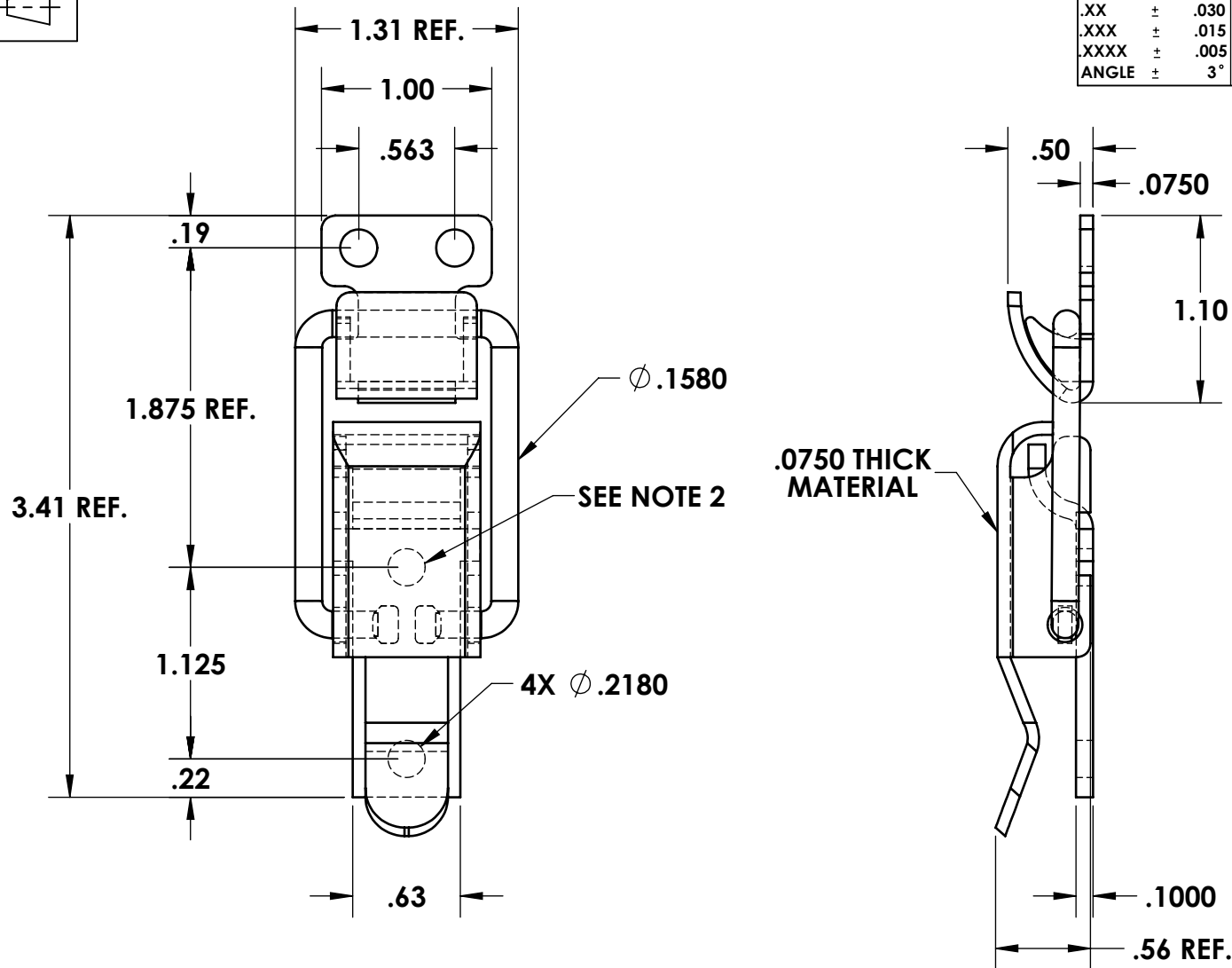

**NOTES:**

1. FINISH: 00- NO FINISH
2. HOLE PUNCHED PRIMARY .2180 DIA, HOLE DIA. MAY DECREASE AFTER FORMING

REV.	DESCRIPTION	DATE	APPD
D	VARIOUS CHANGES	11/14/2019	JG
C	CONVERTED	01/23/2018	JG
B	VARIOUS CHANGES	08/01/2013	JG

REVISIONS

DWG #:		SCALE	1:1	CODE IDENT. #
<b>8333-32</b>		DATE	06/22/1998	03007
MATERIAL:	FINISH:	 <b>GUDEN</b> INDUSTRIAL HARDWARE MADE EASY 99 RAYNOR AVE. RONKONKOMA, N.Y. 11779 1-800-3-HINGES		
304-ST	SEE NOTE			
DR. BY: RAG	CK. BY: CD			
FAX: 1-631-737-2933 EMAIL: info@guden.com WEB: www.guden.com				