

A
SIZE

PROJECTIONS



TOLERANCES UNLESS OTHERWISE SPECIFIED:

PLACES	INCH
.XX	± .030
.XXX	± .015
.XXXX	± .005
ANGLE	3°

NOTE:
ACCEPTABLE BURR ± 10% OF MATERIAL THICKNESS
ALL TOLERANCES ARE NON-CUMULATIVE
ALL DIMENSIONS APPLY TO PART BEFORE ANY FINISH IS APPLIED

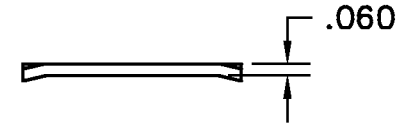
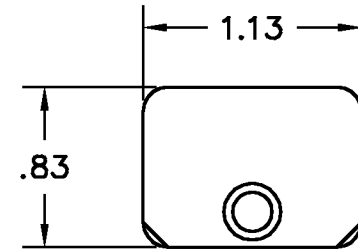
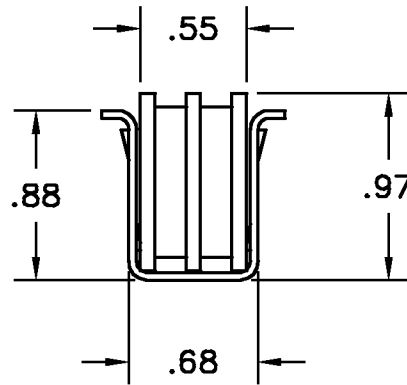
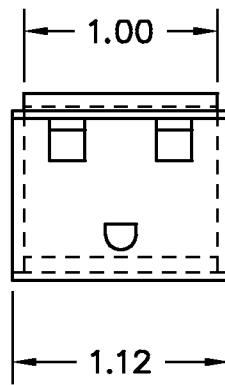
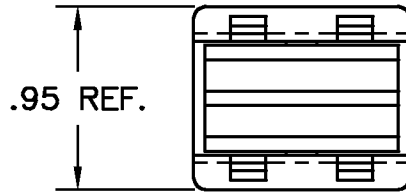

NOTES:

1. FINISH: 90- BARREL ZINC & CLEAR CHROMATE (STRIKE ONLY)
2. MATERIAL: STRIKE = PS
CATCH = ALUM CASE WITH SELF-ALIGNING LIFETIME MAGNETS
3. MOUNTING: SNAPS INTO .750 X 1.187 OPENING IN .0625 - .0781 THICK METAL

DWG		SCALE	1:1	CODE IDENT. #
8321-MAG		DATE	08/10/99	03007
MATERIAL	FINISH			
SEE NOTE	SEE NOTE			
DR. BY	CK. BY	99 RAYNOR AVE. RONKONKOMA, N.Y. 11779 1-800-3-HINGES		
FAX: 1-631-737-2933 EMAIL: info@guden.com WEB: www.guden.com				

A	DESCRIPTION	DATE	APPD
	REDRAWN, VARIOUS CHANGES	08/10/99	CD
LTR	REVISION		