

A
SIZE

PROJECTIONS

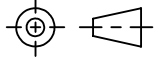

TOLERANCES UNLESS OTHERWISE SPECIFIED:

PLACES	INCHES	NOTES:
.XX	± .030	ACCEPTABLE BURR ± 10% OF MATERIAL THICKNESS
.XXX	± .015	ALL TOLERANCES ARE NON-CUMULATIVE
.XXXX	± .005	ALL DIMENSIONS APPLY TO PART BEFORE ANY FINISH IS APPLIED
ANGLE	± 3°	

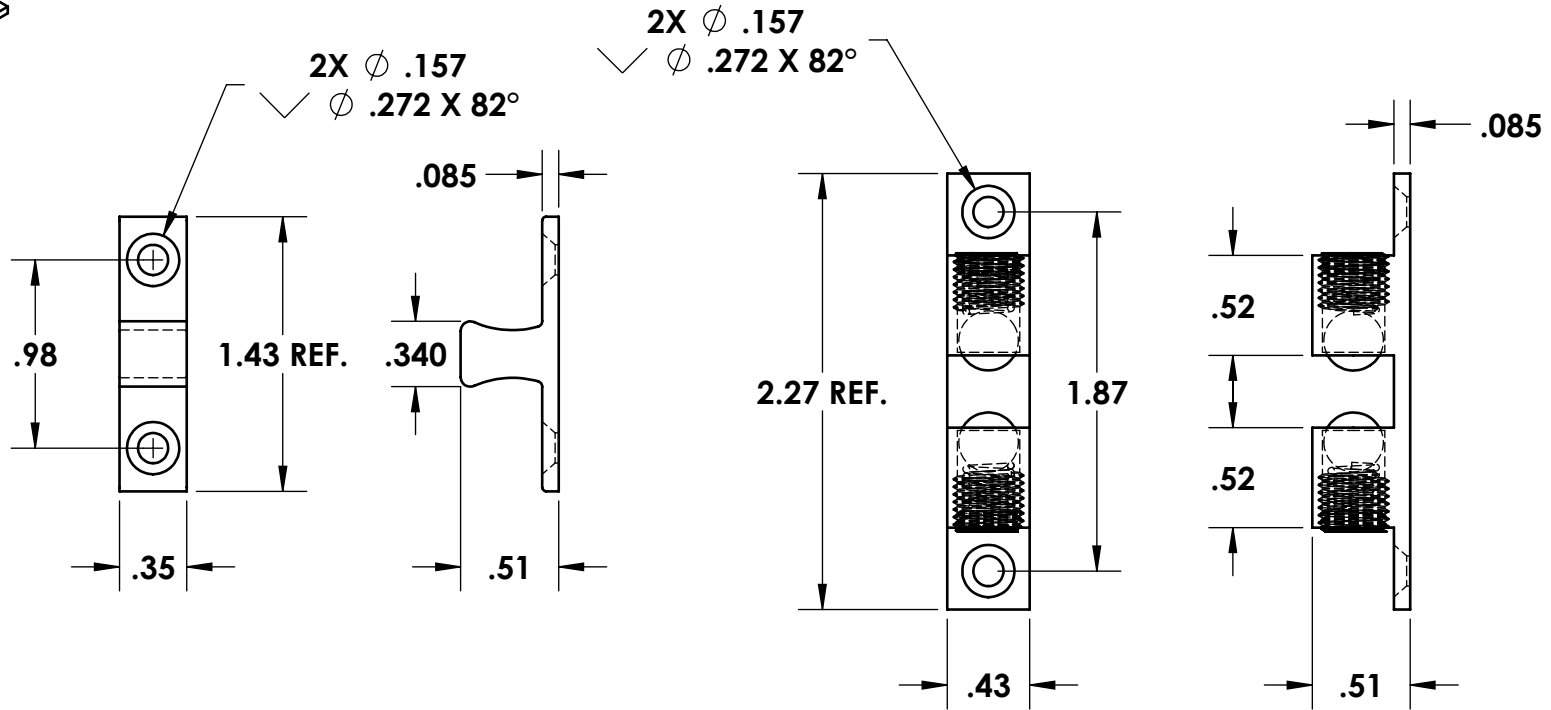
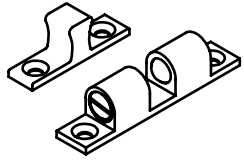

NOTES:

1. FINISH: 78- SATIN NICKEL
2. MATERIAL: BODY, STRIKE, AND ADJUSTER SCREW = BRASS
SPRING = SPRING STEEL
BALL = CHROME PLATED STEEL

<p>DWG #: 3C-26D</p>				SCALE	1:1	CODE IDENT. #
				DATE	06/03/2003	03007
C	CONVERTED	07/21/2017	JG	<p>GUDEN INDUSTRIAL HARDWARE MADE EASY 99 RAYNOR AVE. RONKONKOMA, N.Y. 11779 1-800-3-HINGES</p>		
B	FINISH AND MATERIAL	03/10/2014	JG			
A	VARIOUS CHANGES	02/26/2013	JG			
REV.	DESCRIPTION	DATE	APPD			
REVISIONS				<p>MATERIAL: SEE NOTE FINISH: SEE NOTE</p> <p>DR. BY: RAG CK. BY: CD</p> <p>FAX: 1-631-737-2933</p> <p>EMAIL: info@guden.com</p> <p>WEB: www.guden.com</p>		