

A
SIZE

PROJECTIONS

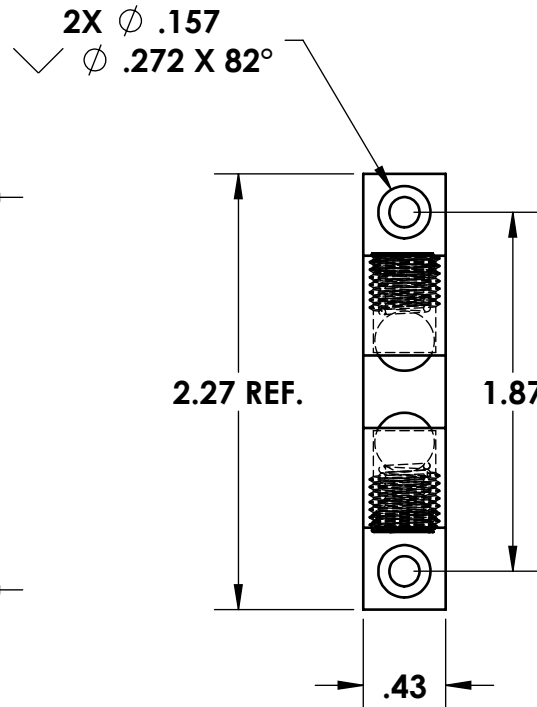
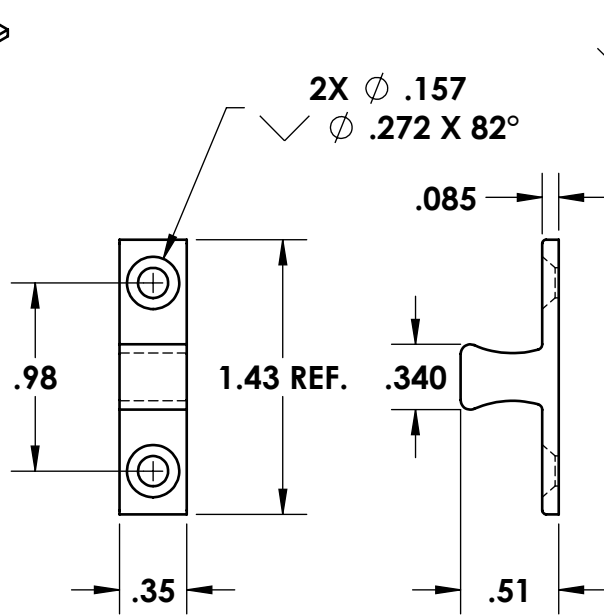
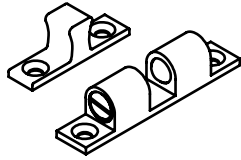
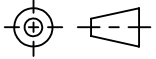

TOLERANCES UNLESS OTHERWISE SPECIFIED:

PLACES	INCHES	NOTES:
.XX	± .030	ACCEPTABLE BURR ± 10% OF MATERIAL THICKNESS
.XXX	± .015	ALL TOLERANCES ARE NON-CUMULATIVE
.XXXX	± .005	ALL DIMENSIONS APPLY TO PART BEFORE ANY FINISH IS APPLIED
ANGLE	± 3°	

NOTES:

- FINISH: 05- SATIN AND LACQUER
- MATERIAL: BODY, STRIKE, AND ADJUSTER SCREW = BRASS
SPRING = SPRING STEEL
BALL = CHROME PLATED STEEL

REV. DESCRIPTION DATE APPD				DWG #:	SCALE	1:1	CODE IDENT. #
C	CONVERTED	07/21/2017	JG	3C-04	DATE	06/03/2003	03007
B	FINISH AND MATERIAL	03/10/2014	JG		MATERIAL: SEE NOTE	FINISH: SEE NOTE	
A	VARIOUS CHANGES	02/26/2013	JG	DR. BY: RAG	CK. BY: CD		
REV.	DESCRIPTION	DATE	APPD	FAX: 1-631-737-2933 EMAIL: info@guden.com WEB: www.guden.com		GUDEN INDUSTRIAL HARDWARE MADE EASY 99 RAYNOR AVE. RONKONKOMA, N.Y. 11779 1-800-3-HINGES	
REVISIONS							