

A
SIZE

PROJECTIONS

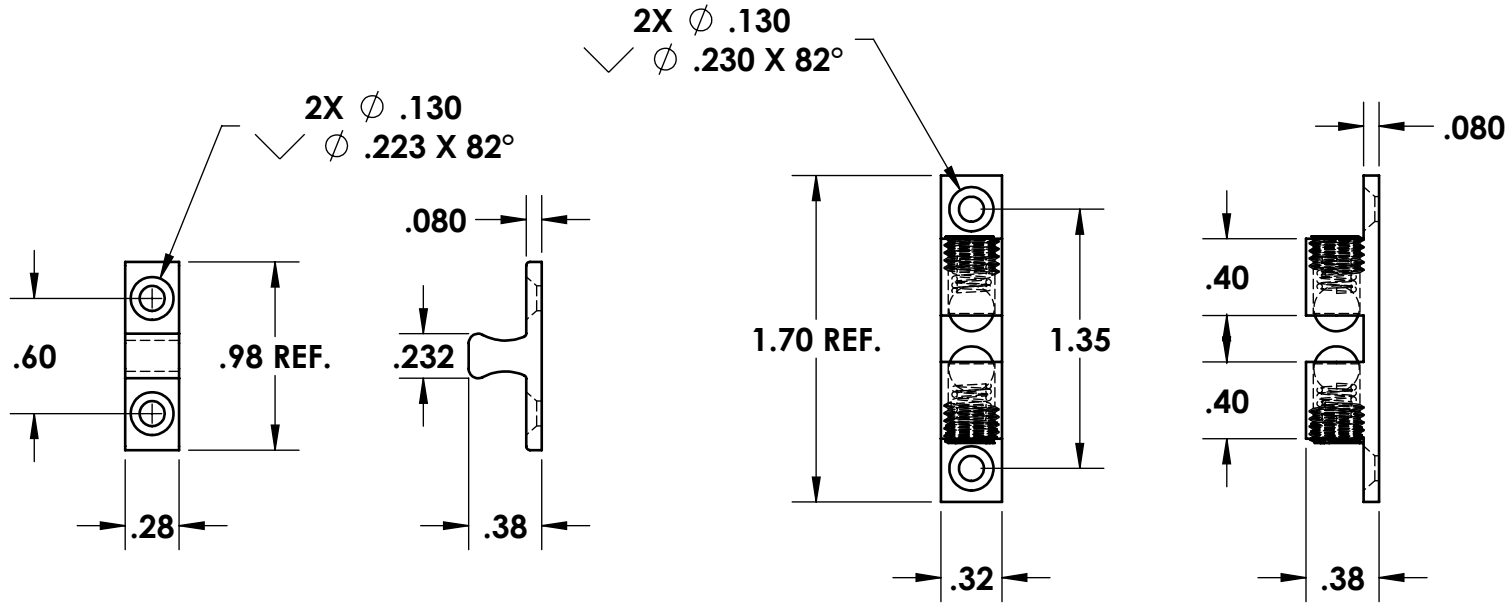
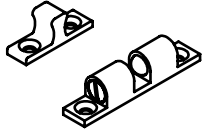

TOLERANCES UNLESS OTHERWISE SPECIFIED:

PLACES	INCHES	NOTES:
.XX	± .030	ACCEPTABLE BURR ± 10% OF MATERIAL THICKNESS
.XXX	± .015	ALL TOLERANCES ARE NON-CUMULATIVE
.XXXX	± .005	ALL DIMENSIONS APPLY TO PART BEFORE ANY FINISH IS APPLIED
ANGLE	± 3°	

NOTES:

1. FINISH: 78- SATIN NICKEL
2. MATERIAL: BODY, STRIKE, AND ADJUSTER SCREW = BRASS
SPRING = SPRING STEEL
BALL = CHROME PLATED STEEL

DWG #:		SCALE	1:1	CODE IDENT. #
1C-26D		DATE	06/04/2003	03007
		 99 RAYNOR AVE. RONKONKOMA, N.Y. 11779 1-800-3-HINGES		
MATERIAL:	FINISH:			
SEE NOTE	SEE NOTE			
DR. BY: RAG	CK. BY: CD			
FAX: 1-631-737-2933				
EMAIL: info@guden.com				
WEB: www.guden.com				

REV.	DESCRIPTION	DATE	APPD
B	CONVERTED	07/20/2017	JG
A	FINISH AND MATERIAL	03/10/2014	JG
REVISIONS			