

A
SIZE

PROJECTIONS

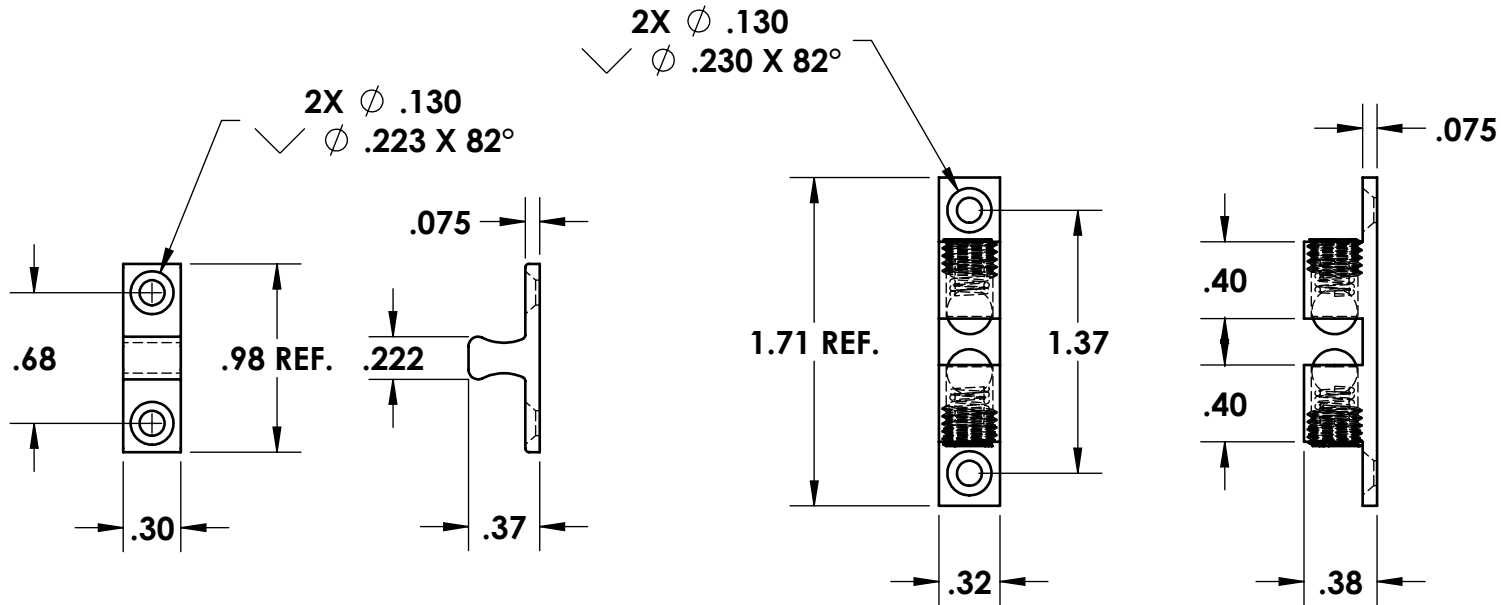
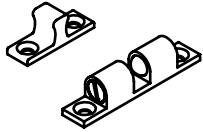

TOLERANCES UNLESS OTHERWISE SPECIFIED:

PLACES	INCHES	NOTES:
.XX	± .030	ACCEPTABLE BURR ± 10% OF MATERIAL THICKNESS
.XXX	± .015	ALL TOLERANCES ARE NON-CUMULATIVE
.XXXX	± .005	ALL DIMENSIONS APPLY TO PART BEFORE ANY FINISH IS APPLIED
ANGLE	± 3°	

NOTES:

1. FINISH: 05- SATIN AND LACQUERED
2. MATERIAL: BODY, STRIKE, AND ADJUSTER SCREW = BRASS
 SPRING = SPRING STEEL
 BALL = CHROME PLATED STEEL

<p>DWG #: 1C-04</p>				SCALE	1:1	CODE IDENT. #
				DATE	06/04/2003	03007
D	VARIOUS CHANGES	10/31/2019	JG	 GUDEN INDUSTRIAL HARDWARE MADE EASY 99 RAYNOR AVE. RONKONKOMA, N.Y. 11779 1-800-3-HINGES		
C	CONVERTED	07/20/2017	JG			
B	CHANGED FINISH AND MATERIAL	03/10/2014	JG			
REV.	DESCRIPTION	DATE	APPD			
REVISIONS				MATERIAL: SEE NOTE FINISH: SEE NOTE DR. BY: RAG CK. BY: CD FAX: 1-631-737-2933 EMAIL: info@guden.com WEB: www.guden.com		