

A
SIZE

PROJECTIONS



TOLERANCES UNLESS OTHERWISE SPECIFIED:

PLACES	INCH
.XX	± .030
.XXX	± .015
.XXXX	± .005
ANGLE	3°

NOTE:
ACCEPTABLE BURR ± 10% OF MATERIAL THICKNESS
ALL TOLERANCES ARE NON-CUMULATIVE
ALL DIMENSIONS APPLY TO PART BEFORE ANY FINISH IS APPLIED

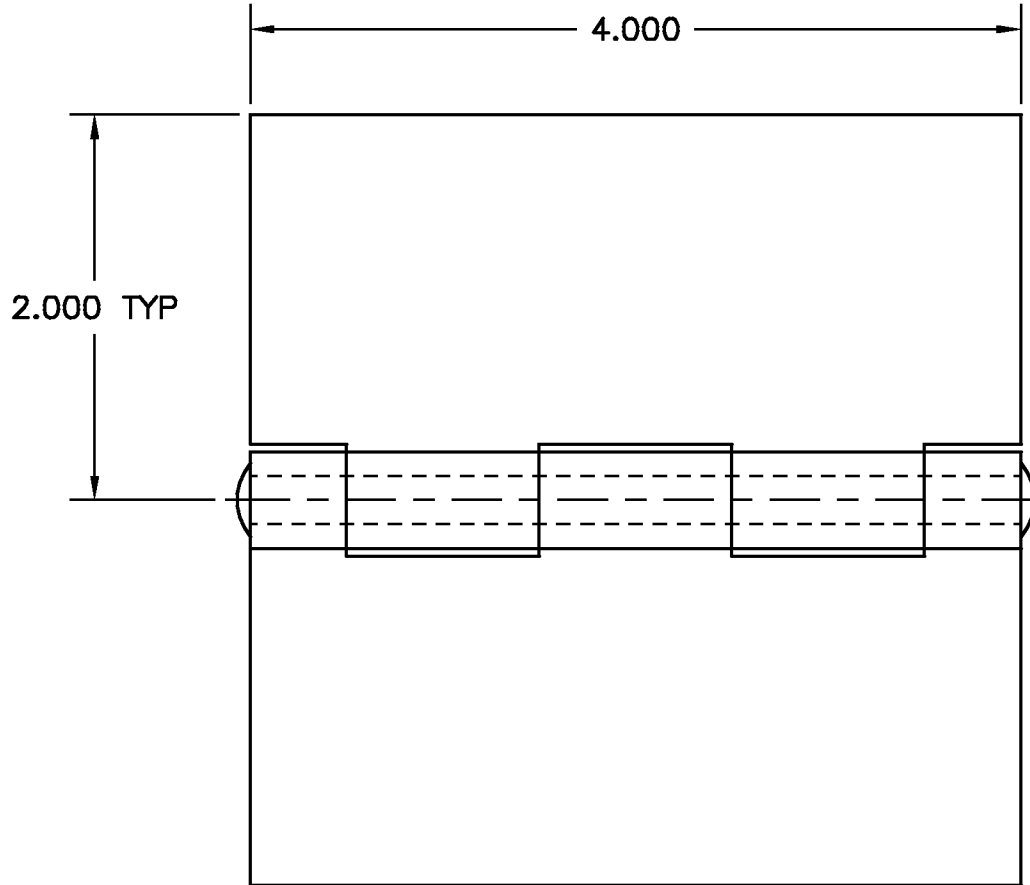

.2500 DIA PIN
SPUN BOTH ENDS

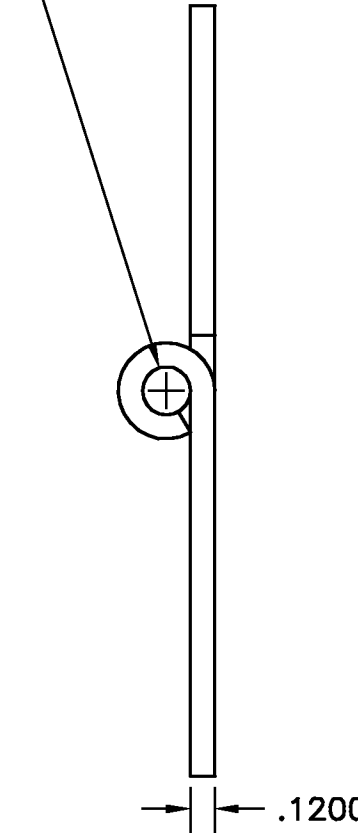

- NOTES:
1. FINISH: 00- NO FINISH
2. MATERIAL: LEAVES = ALUM
PIN = STS

DWG		SCALE	1:1	CODE IDENT. #
9000401225		DATE	04/09/96	03007
MATERIAL	FINISH			
SEE NOTE	SEE NOTE			
DR. BY RAG	CK. BY CD	99 RAYNOR AVE. RONKONKOMA, N.Y. 11779 1-800-3-HINGES		
FAX: 1-631-737-2933 EMAIL: info@guden.com WEB: www.guden.com				
REVISION				

A	MATERIAL THICKNESS	10/27/11	JG
LTR	DESCRIPTION	DATE	APPD
	REVISION		