

A
SIZE

PROJECTIONS



TOLERANCES UNLESS OTHERWISE SPECIFIED:

PLACES	INCH	NOTE:
.XX	± .030	ACCEPTABLE BURR ± 10% OF MATERIAL THICKNESS ALL TOLERANCES ARE NON-CUMULATIVE ALL DIMENSIONS APPLY TO PART BEFORE ANY FINISH IS APPLIED
.XXX	± .015	
.XXXX	± .005	
ANGLE	3°	

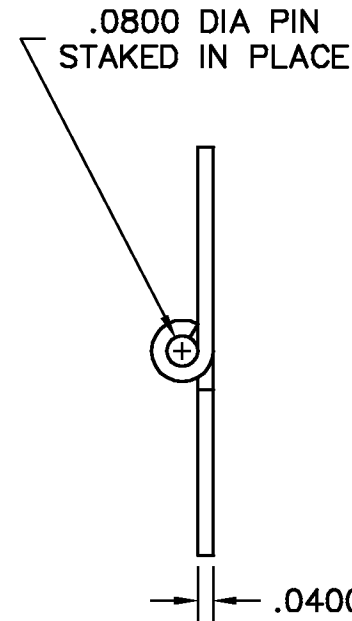
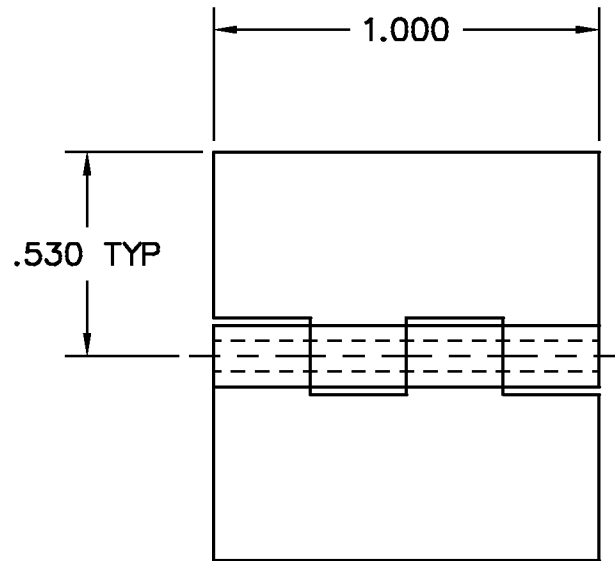

- NOTES:
 1. FINISH: 00- NO FINISH
 2. KNUCKLES: .25 TYP

DWG 9000100408		SCALE 2:1	CODE IDENT. # 03007
MATERIAL ALUM		FINISH SEE NOTE	
DR. BY RAG		CK. BY CD	
FAX: 1-631-737-2933 EMAIL: info@guden.com WEB: www.guden.com		GUDEN DELIVERING HARDWARE EXCELLENCE 99 RAYNOR AVE. RONKONKOMA, N.Y. 11779 1-800-3-HINGES	

LTR	DESCRIPTION	DATE	APPD
	REVISION		