

A
SIZE

PROJECTIONS

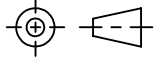

TOLERANCES UNLESS OTHERWISE SPECIFIED:

PLACES	INCHES	NOTES:
.XX	± .030	ACCEPTABLE BURR ± 10% OF MATERIAL THICKNESS
.XXX	± .015	ALL TOLERANCES ARE NON-CUMULATIVE
.XXXX	± .005	ALL DIMENSIONS APPLY TO PART BEFORE ANY FINISH IS APPLIED
ANGLE	± 3°	

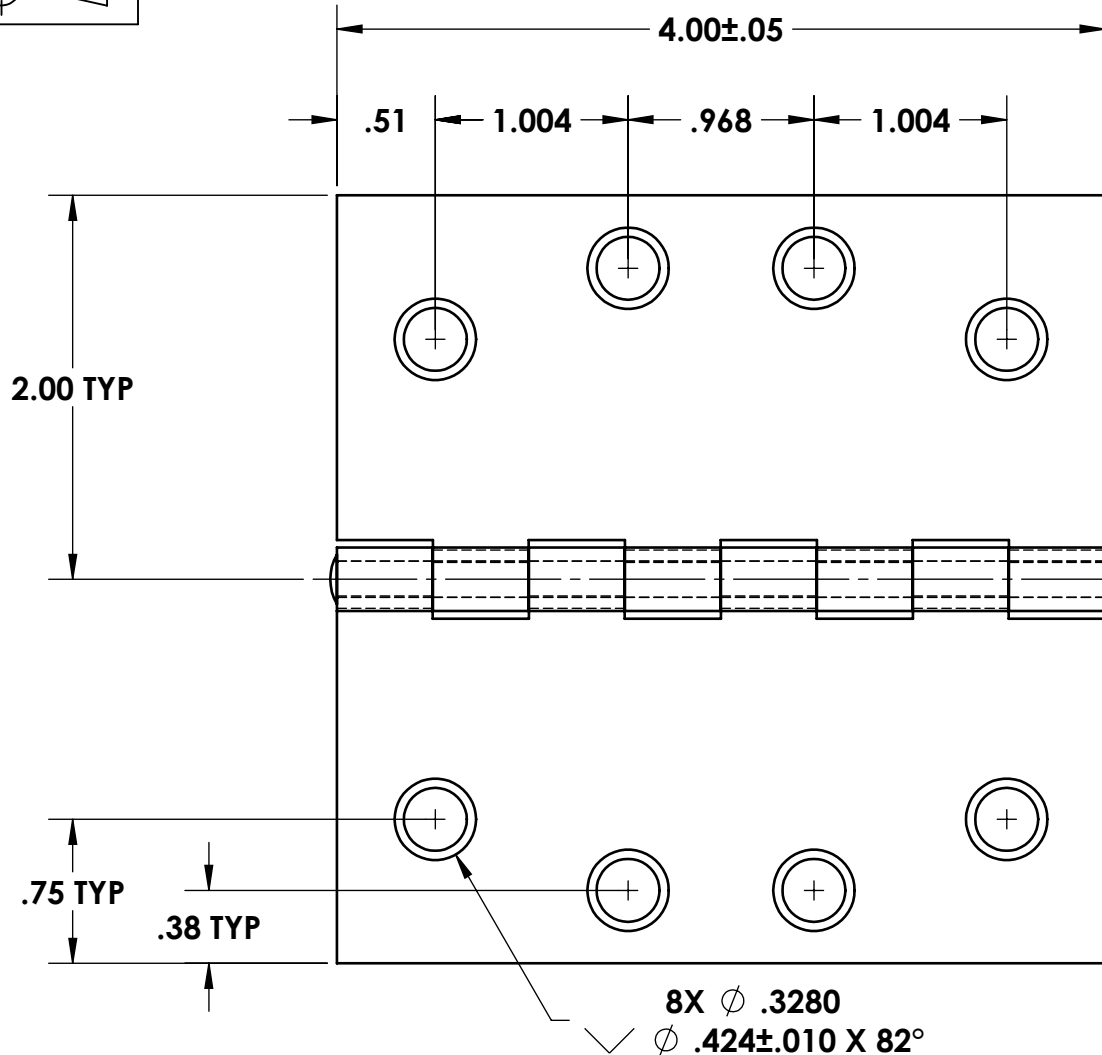

Ø .1870 PIN
SPUN BOTH ENDS

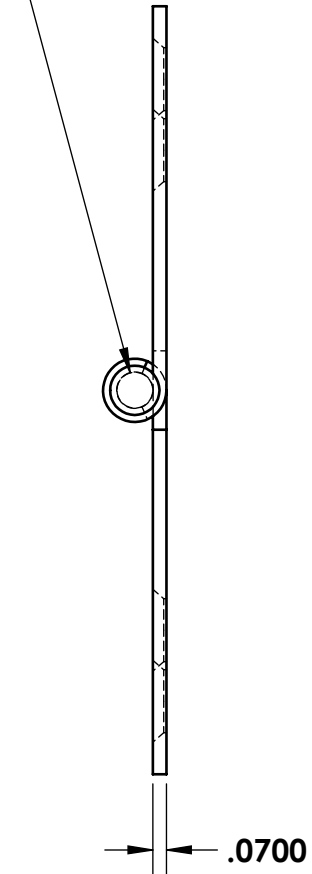

- NOTES:
 1. FINISH: 00- NO FINISH
 2. KNUCKLE CONFIGURATION MAY VARY FROM PRINT

REV.	DESCRIPTION	DATE	APPD
F	MATERIAL THICKNESS	03/25/2020	JG
E	KNUCKLE CONFIGURATION	5/22/2014	JG
D	HOLE DIA.	04/01/2014	JG

REVISIONS

DWG #:		SCALE	1:1	CODE IDENT. #
8000400718		DATE	09/26/2001	03007
MATERIAL:	FINISH:	 99 RAYNOR AVE. RONKONKOMA, N.Y. 11779 1-800-3-HINGES		
304-ST	SEE NOTE			
DR. BY: RAG	CK. BY: CD			
FAX: 1-631-737-2933 EMAIL: info@guden.com WEB: www.guden.com				