

A
SIZE

PROJECTIONS

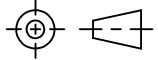

TOLERANCES UNLESS OTHERWISE SPECIFIED:

PLACES	INCHES	NOTES:
.XX	± .030	ACCEPTABLE BURR ± 10% OF MATERIAL THICKNESS
.XXX	± .015	ALL TOLERANCES ARE NON-CUMULATIVE
.XXXX	± .005	ALL DIMENSIONS APPLY TO PART BEFORE ANY
ANGLE	± 3°	FINISH IS APPLIED

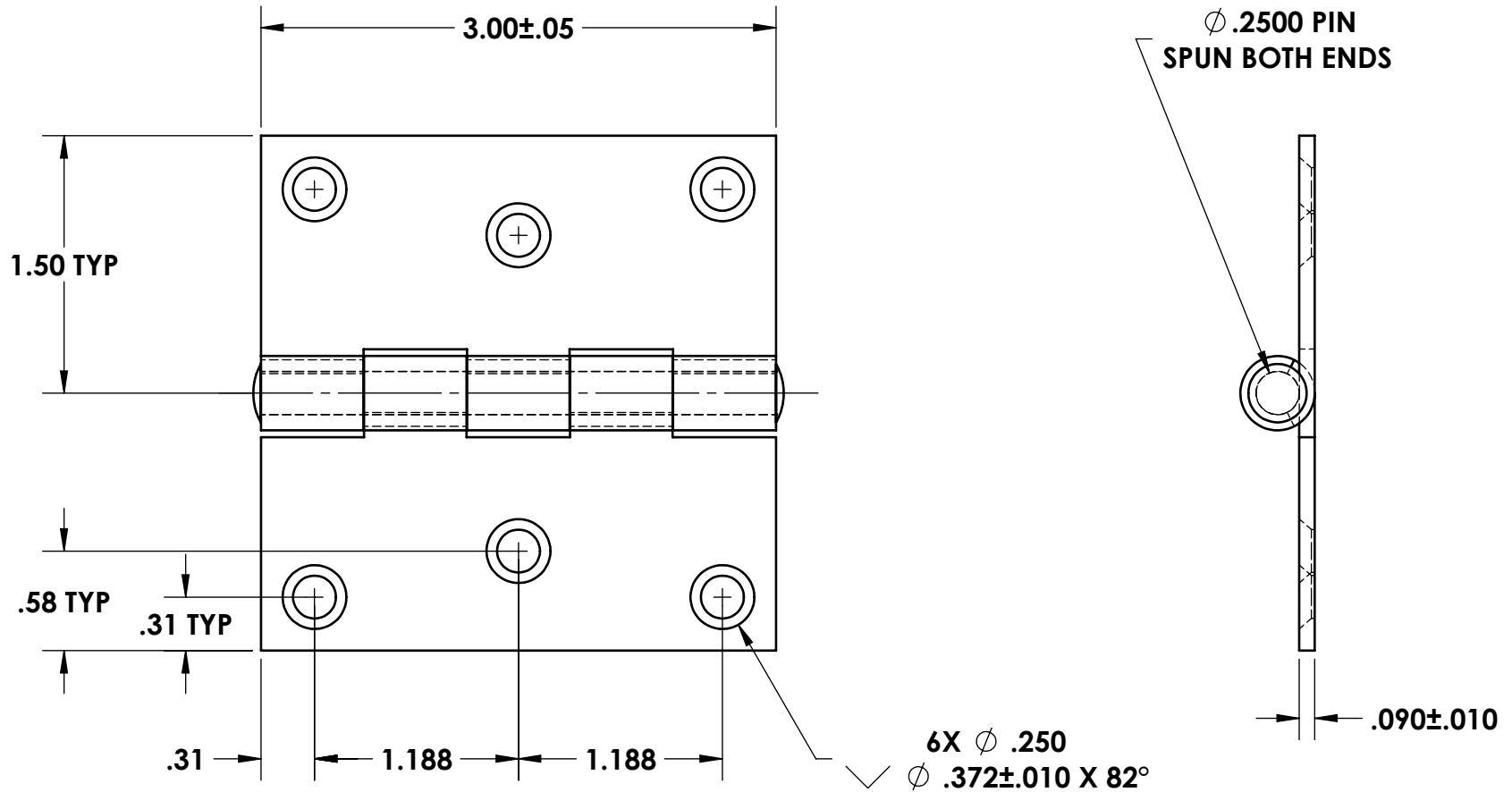

NOTES:

1. FINISH: 00- NO FINISH
2. KNUCKLE CONFIGURATION MAY VARY FROM PRINT

REV.	DESCRIPTION	DATE	APPD
E	VARIOUS CHANGES	05/07/2019	JG
D	CORRECTED # OF HOLES	09/17/2007	CD
C	MATERIAL THICK, NOTE 2	10/28/2005	CD

REVISIONS

DWG #:		SCALE	1:1	CODE IDENT. #
8000300925		DATE	12/23/1998	03007
MATERIAL:	FINISH:	 GUDEN INDUSTRIAL HARDWARE MADE EASY 99 RAYNOR AVE. RONKONKOMA, N.Y. 11779 1-800-3-HINGES		
304-ST	SEE NOTE			
DR. BY: RAG	CK. BY: CD			
FAX: 1-631-737-2933 EMAIL: info@guden.com WEB: www.guden.com				