

**A**  
SIZE

PROJECTIONS



TOLERANCES UNLESS OTHERWISE SPECIFIED:

PLACES	INCH
.XX	± .030
.XXX	± .015
.XXXX	± .005
ANGLE	3°

NOTE:  
ACCEPTABLE BURR ± 10% OF MATERIAL THICKNESS  
ALL TOLERANCES ARE NON-CUMULATIVE  
ALL DIMENSIONS APPLY TO PART BEFORE ANY FINISH IS APPLIED

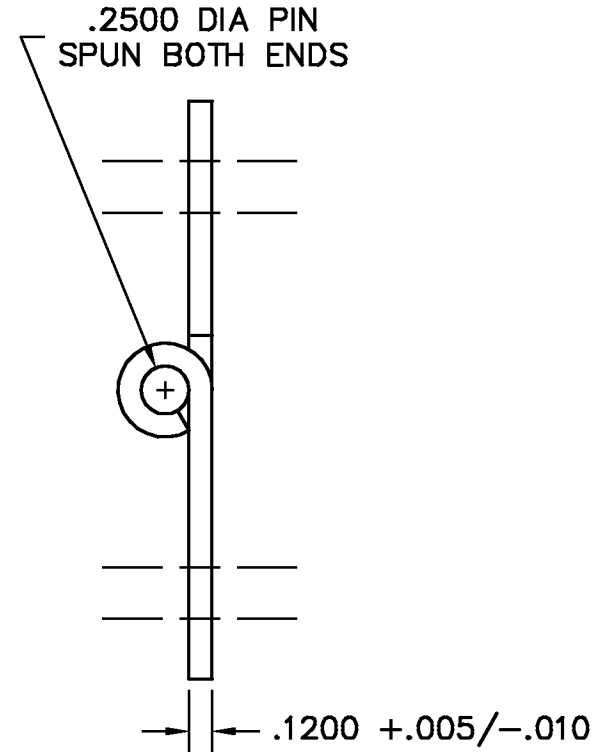
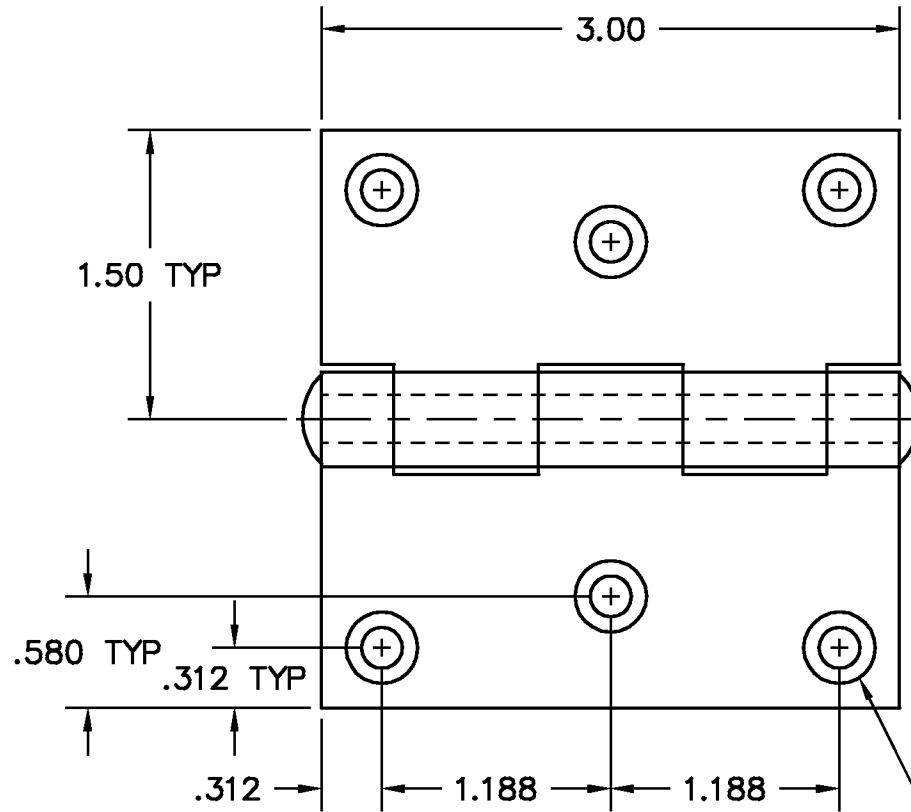

CTSK 82° FOR #10 FHS  
(6) PLACES

NOTES:

1. FINISH: 00- NO FINISH
2. KNUCKLE CONFIGURATION MAY VARY FROM PRINT

LTR	DESCRIPTION	DATE	APPD
F	VARIOUS CHANGES	07/21/16	JG
E	MATERIAL THICKNESS	04/01/13	JG
D	MATERIAL THICKNESS	05/03/07	CD
C	MATERIAL THICK, NOTE 2	10/28/05	CD
B	REDRAWN	12/23/98	CD

REVISION

DWG		SCALE	1:1	CODE IDENT. #
8000301225		DATE	12/23/98	03007
MATERIAL	FINISH			
STS	SEE NOTE			
DR. BY RAG	CK. BY CD	99 RAYNOR AVE. RONKONKOMA, N.Y. 11779 1-800-3-HINGES		
FAX: 1-631-737-2933 EMAIL: info@guden.com WEB: www.guden.com				