

A
SIZE

PROJECTIONS

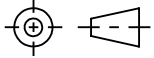

TOLERANCES UNLESS OTHERWISE SPECIFIED:

PLACES	INCHES	NOTES:
.XX	± .030	ACCEPTABLE BURR ± 10% OF MATERIAL THICKNESS
.XXX	± .015	ALL TOLERANCES ARE NON-CUMULATIVE
.XXXX	± .005	ALL DIMENSIONS APPLY TO PART BEFORE ANY
ANGLE	± 3°	FINISH IS APPLIED

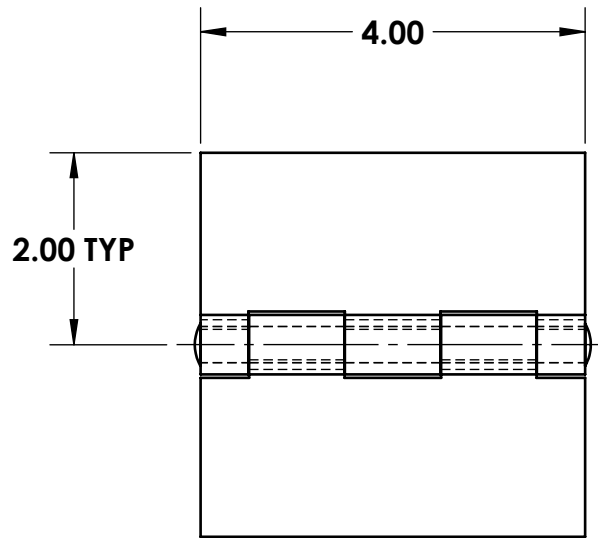

Ø .3750 PIN
SPUN BOTH ENDS

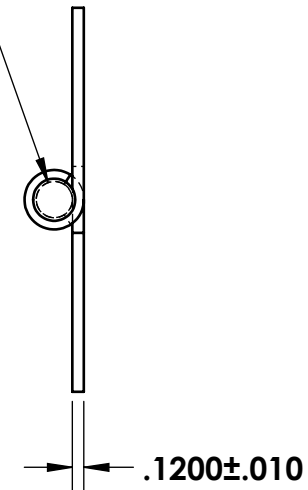

NOTES:

1. FINISH: 00- NO FINISH
2. KNUCKLE CONFIGURATION MAY VARY FROM PRINT

REV.	DESCRIPTION	DATE	APPD
B	VARIOUS CHANGES	01/03/2024	JG
A	MATERIAL THICKNESS	05/03/2007	CD

REVISIONS

DWG #:

7000401237

MATERIAL:
304-ST

FINISH:
SEE NOTE

DR. BY: RAG

CK. BY: CD

FAX: 1-631-737-2933
EMAIL: info@guden.com
WEB: www.guden.com

SCALE

1:2

CODE IDENT. #

DATE

04/22/1996

03007

GUDEN
INDUSTRIAL HARDWARE MADE EASY

99 RAYNOR AVE.
RONKONKOMA, N.Y. 11779
1-800-3-HINGES