

A
SIZE

PROJECTIONS



TOLERANCES UNLESS OTHERWISE SPECIFIED:

PLACES	INCH
.XX	± .030
.XXX	± .015
.XXXX	± .005
ANGLE	3°

NOTE:
ACCEPTABLE BURR ± 10% OF MATERIAL THICKNESS
ALL TOLERANCES ARE NON-CUMULATIVE
ALL DIMENSIONS APPLY TO PART BEFORE ANY FINISH IS APPLIED

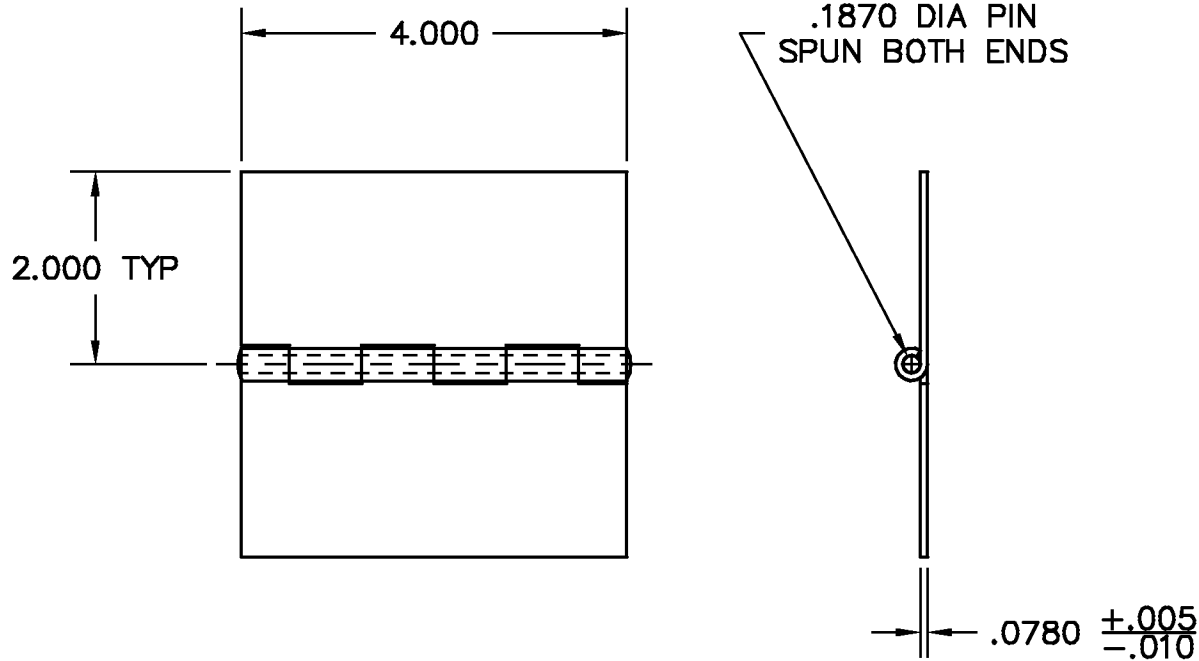

NOTES:

1. FINISH: 00- NO FINISH
2. KNUCKLE CONFIG. MAY VARY FROM PRINT

DWG 6000400718		SCALE 1:2	CODE IDENT. # 03007
MATERIAL PS	FINISH SEE NOTE		
DR. BY RAG	CK. BY CD		
FAX: 1-631-737-2933 EMAIL: info@guden.com WEB: www.guden.com		99 RAYNOR AVE. RONKONKOMA, N.Y. 11779 1-800-3-HINGES	

A	MATERIAL THICK, NOTE 2	11/13/15	JG
LTR	DESCRIPTION	DATE	APPD
REVISION			