

**A**  
SIZE

PROJECTIONS

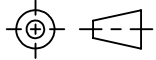

TOLERANCES UNLESS OTHERWISE SPECIFIED:

PLACES	INCHES	NOTES:
.XX	± .030	ACCEPTABLE BURR ± 10% OF MATERIAL THICKNESS
.XXX	± .015	ALL TOLERANCES ARE NON-CUMULATIVE
.XXXX	± .005	ALL DIMENSIONS APPLY TO PART BEFORE ANY
ANGLE	± 3°	FINISH IS APPLIED

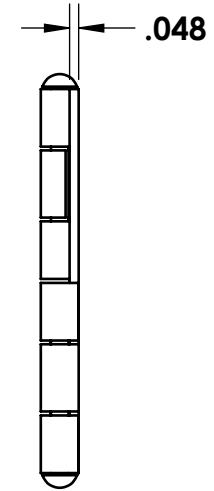
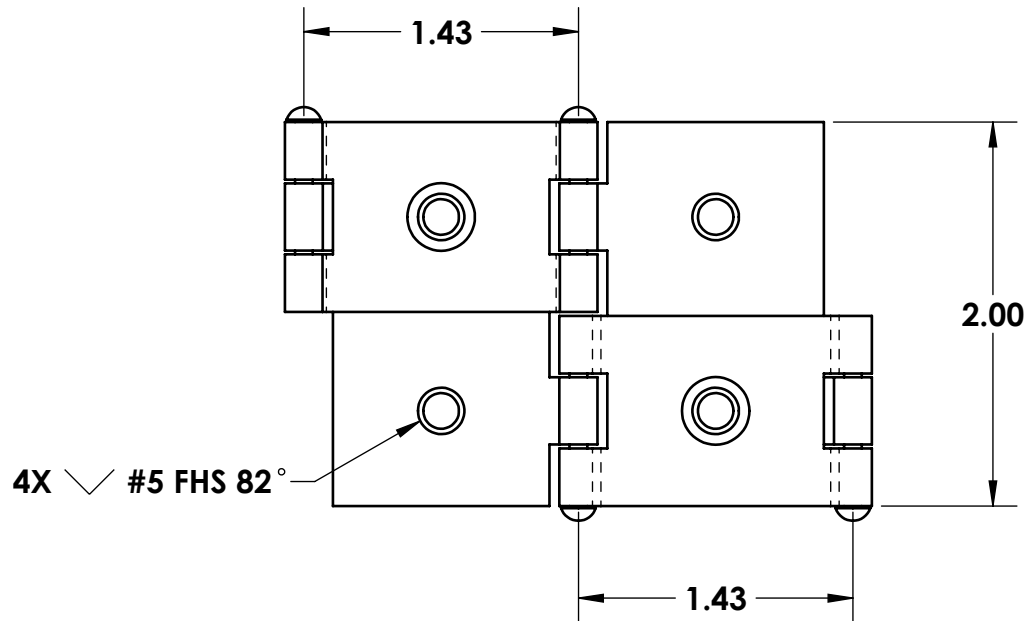

**NOTES:**

1. FINISH: 31- BARREL BRASS BRITE BURNISH AND LACQUER
2. FOR USE WITH 1.25 PANEL

DWG #:  
**BIFOLD551-125**

SCALE	1:1	CODE IDENT. #
DATE	05/24/2018	03007

MATERIAL: PS      FINISH: SEE NOTE  
 DR. BY: RAG      CK. BY: JPG

**GUDEN**  
 INDUSTRIAL HARDWARE MADE EASY

FAX: 1-631-737-2933  
 EMAIL: info@guden.com  
 WEB: www.guden.com

99 RAYNOR AVE.  
 RONKONKOMA, N.Y. 11779  
 1-800-3-HINGES

REV.	DESCRIPTION	DATE	APPD
REVISIONS			