

A
SIZE

PROJECTIONS



TOLERANCES UNLESS OTHERWISE SPECIFIED:

PLACES	INCH
.XX	± .030
.XXX	± .015
.XXXX	± .005
ANGLE	3°

NOTE:
ACCEPTABLE BURR ± 10% OF MATERIAL THICKNESS
ALL TOLERANCES ARE NON-CUMULATIVE
ALL DIMENSIONS APPLY TO PART BEFORE ANY FINISH IS APPLIED

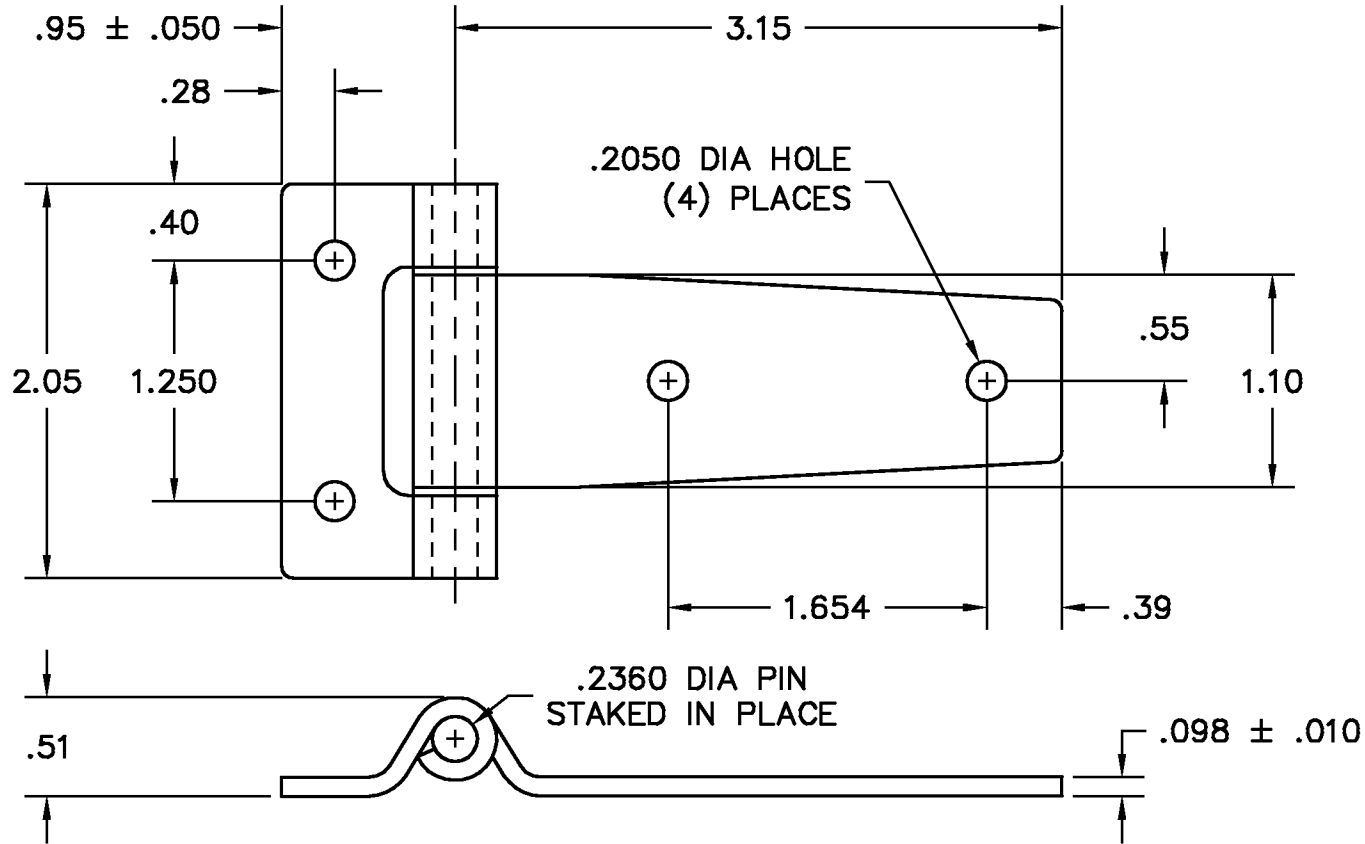

NOTES:
1. FINISH: 12- POLISH - TOPSIDE & KNUCKLE ALL AROUND

DWG STRP0315RVA1		SCALE 1:1	CODE IDENT. # 03007
MATERIAL STS		FINISH SEE NOTE	
DR. BY RAG		CK. BY CD	
FAX: 1-631-737-2933		99 RAYNOR AVE.	
EMAIL: info@guden.com		RONKONKOMA, N.Y. 11779	
WEB: www.guden.com		1-800-3-HINGES	



A	.95 ± .050, .098 ± .010	06/11/10	DW
LTR	DESCRIPTION	DATE	APPD
REVISION			