

A
SIZE

PROJECTIONS

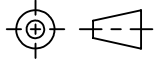

TOLERANCES UNLESS OTHERWISE SPECIFIED:

PLACES	INCHES	NOTES:
.XX	± .030	ACCEPTABLE BURR ± 10% OF MATERIAL THICKNESS
.XXX	± .015	ALL TOLERANCES ARE NON-CUMULATIVE
.XXXX	± .005	ALL DIMENSIONS APPLY TO PART BEFORE ANY FINISH IS APPLIED
ANGLE	± 3°	

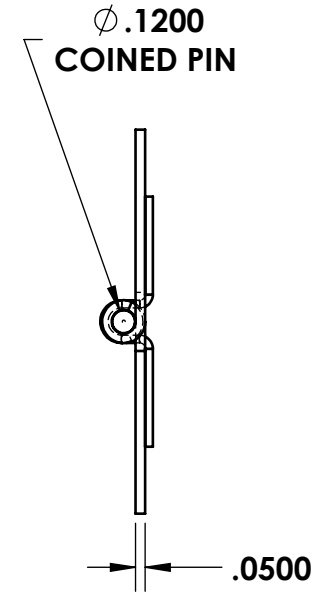
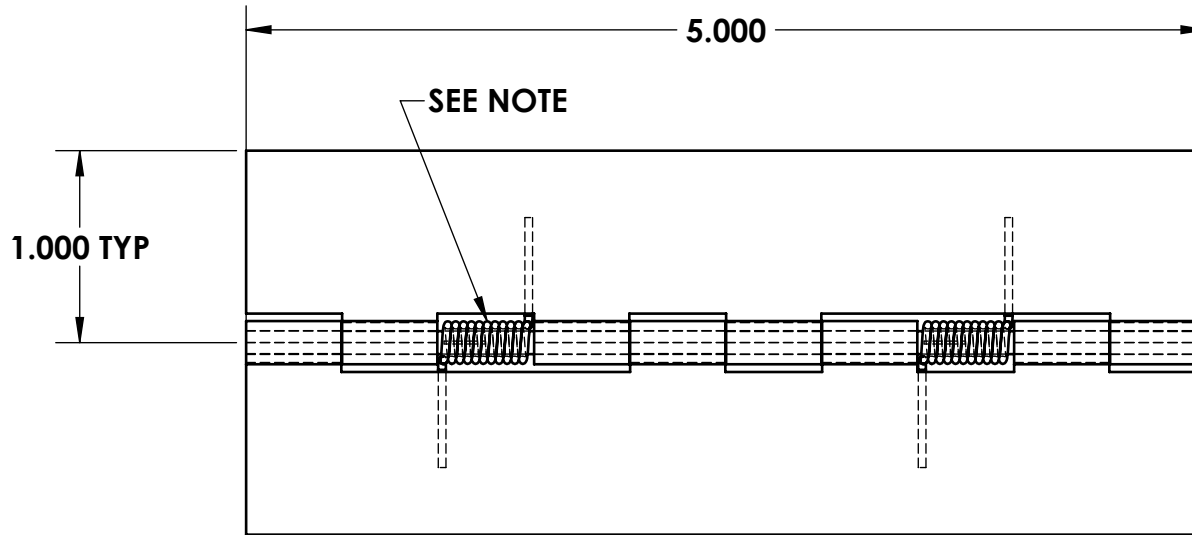

NOTES:

1. FINISH: 361- BRIGHT ANNEALED
2. SPRING: LOADED TO CLOSE, (2) PLACE, .040 WIRE DIA., .56 LEGS
3. KNUCKLES: .50 REF.

REV.	DESCRIPTION	DATE	APPD
B	CONVERTED, FINISH	09/25/2017	JG
A	CHANGED SPRING	12/17/2013	JG
REVISIONS			

DWG #:		SCALE	1:1	CODE IDENT. #
NHSTS1123		DATE	05/09/2001	03007
MATERIAL:	FINISH:	 GUDEN INDUSTRIAL HARDWARE MADE EASY 99 RAYNOR AVE. RONKONKOMA, N.Y. 11779 1-800-3-HINGES		
304-ST5	SEE NOTE			
DR. BY: RAG	CK. BY: CD			
FAX: 1-631-737-2933 EMAIL: info@guden.com WEB: www.guden.com				