

**A**  
SIZE

PROJECTIONS

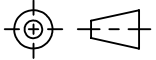

TOLERANCES UNLESS OTHERWISE SPECIFIED:

PLACES	INCHES	NOTES:
.XX	± .030	ACCEPTABLE BURR ± 10% OF MATERIAL THICKNESS
.XXX	± .015	ALL TOLERANCES ARE NON-CUMULATIVE
.XXXX	± .005	ALL DIMENSIONS APPLY TO PART BEFORE ANY FINISH IS APPLIED
ANGLE	± 3°	

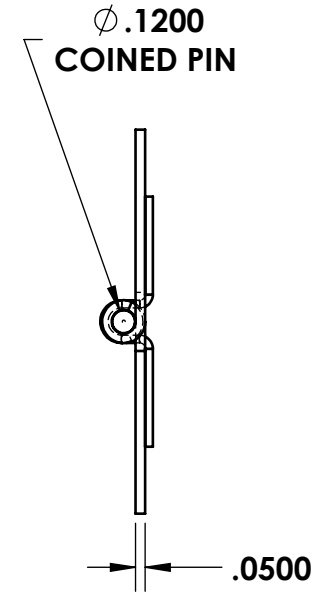
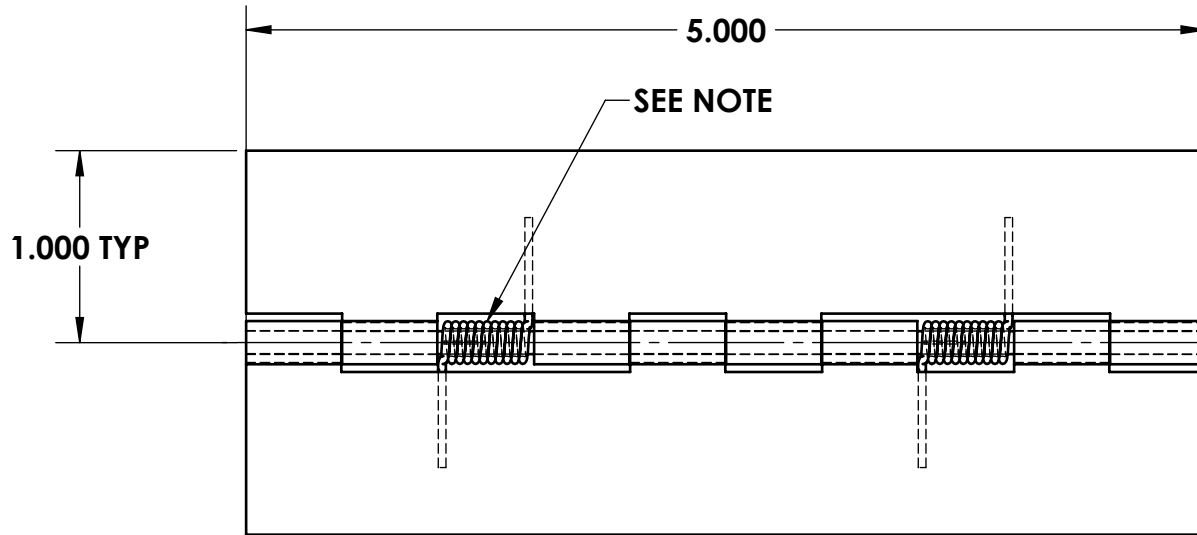

**NOTES:**

1. FINISH: 00- NO FINISH
2. SPRING: LOADED TO CLOSE, (2) PLACE, .040 STS WIRE DIA., .56 LEGS
3. KNUCKLES: .50 REF.

				DWG #:		SCALE	1:1	CODE IDENT. #
				<b>NHPS1123</b>		DATE	05/09/2001	03007
B	CONVERTED, SPRING NOTE	01/10/2018	JG	MATERIAL:	FINISH:			
A	CHANGED SPRING	12/17/2013	JG	PS	SEE NOTE			
REV.	DESCRIPTION	DATE	APPD	DR. BY: RAG	CK. BY: CD			
REVISIONS				FAX: 1-631-737-2933				
				EMAIL: info@guden.com				
				WEB: www.guden.com				