

A
SIZE

PROJECTIONS



TOLERANCES UNLESS OTHERWISE SPECIFIED:

PLACES	INCH
.XX	± .030
.XXX	± .015
.XXXX	± .005
ANGLE	3°

NOTE:
ACCEPTABLE BURR ± 10% OF MATERIAL THICKNESS
ALL TOLERANCES ARE NON-CUMULATIVE
ALL DIMENSIONS APPLY TO PART BEFORE ANY FINISH IS APPLIED

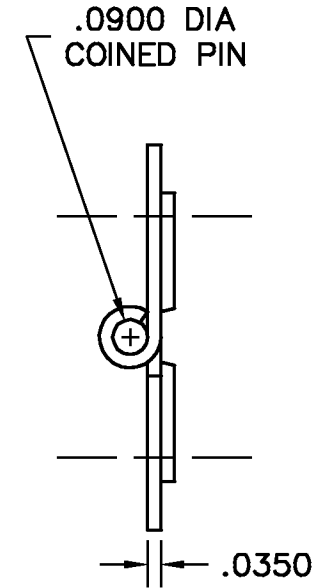
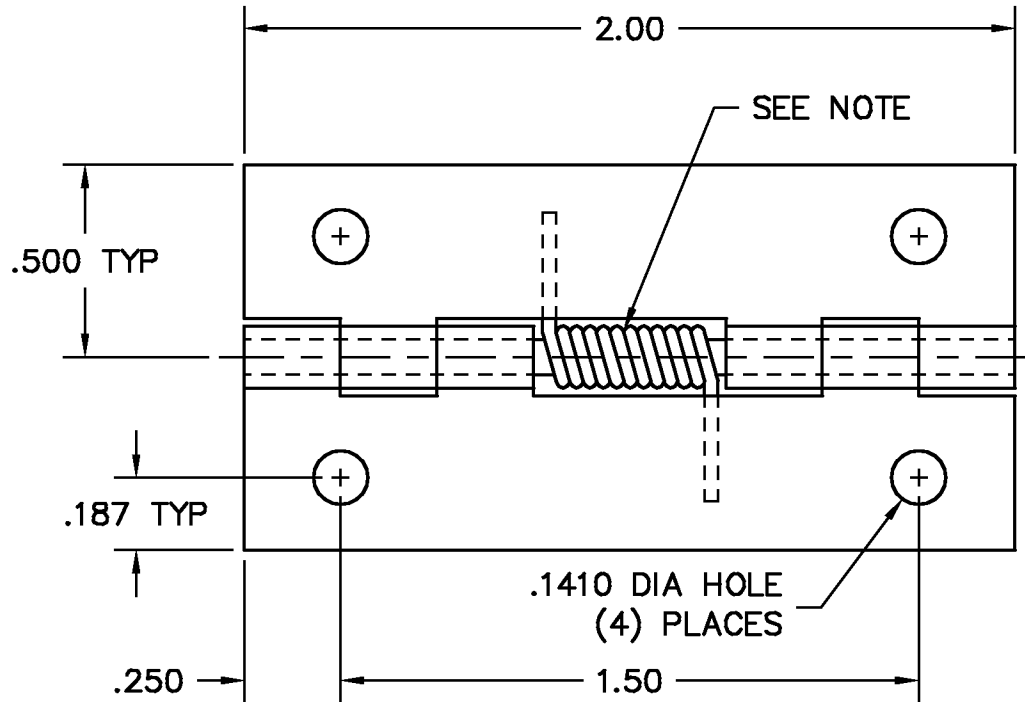

- NOTES:
1. FINISH: 27- VAPOR DEGREASE
2. SPRING: SPR-003 LOADED TO CLOSE, (1) PLACE

DWG		SCALE	2:1	CODE IDENT. #
STS1644035		DATE	09/12/02	03007
MATERIAL	FINISH			
STS	SEE NOTE			
DR. BY RAG	CK. BY CD	99 RAYNOR AVE. RONKONKOMA, N.Y. 11779 1-800-3-HINGES		
FAX: 1-631-737-2933 EMAIL: info@guden.com WEB: www.guden.com				

LTR	DESCRIPTION	DATE	APPD
	REVISION		