

**A**  
SIZE

PROJECTIONS



TOLERANCES UNLESS OTHERWISE SPECIFIED:

PLACES	INCH
.XX	± .030
.XXX	± .015
.XXXX	± .005
ANGLE	3°

NOTE:  
ACCEPTABLE BURR ± 10% OF MATERIAL THICKNESS  
ALL TOLERANCES ARE NON-CUMULATIVE  
ALL DIMENSIONS APPLY TO PART BEFORE ANY FINISH IS APPLIED

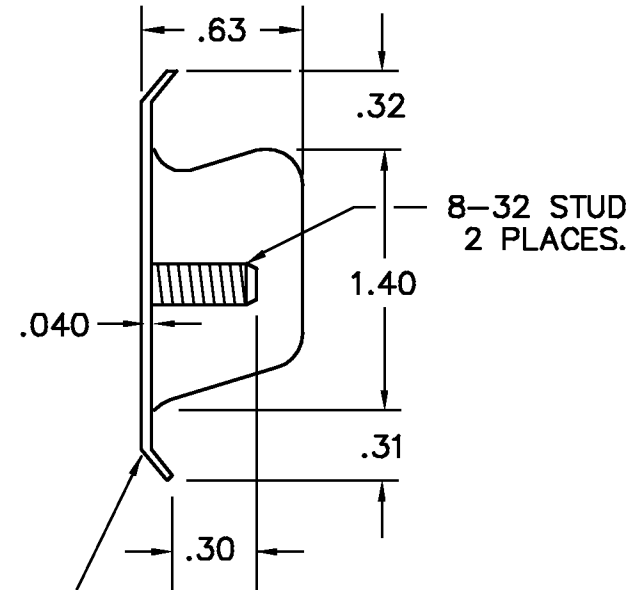
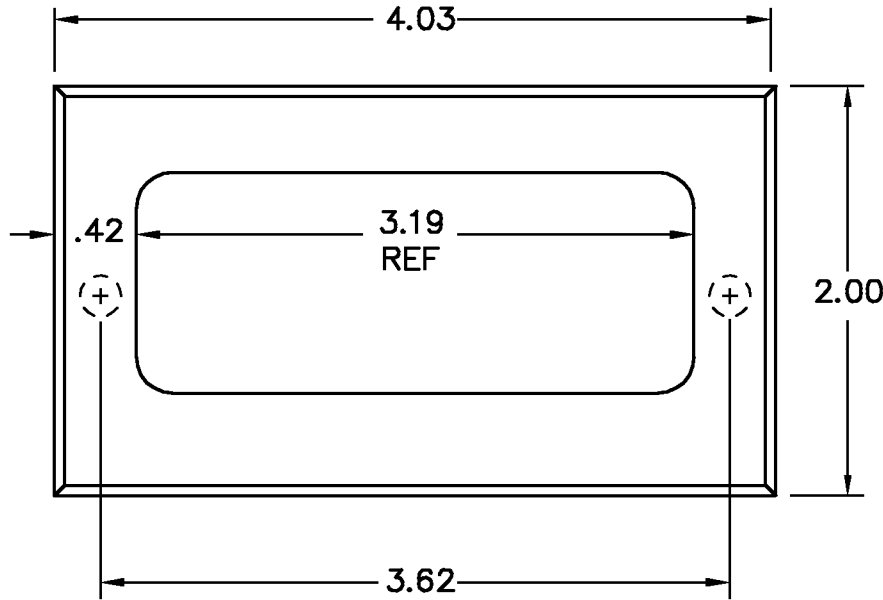

8-32 STUD  
2 PLACES.

BEVELED EDGE

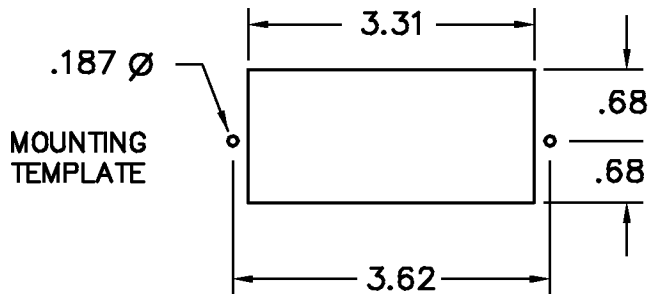

MOUNTING  
TEMPLATE

- NOTES:  
1. FINISH: 29A BRUSHED TOP SIDE ONLY  
2. MATERIAL: PULL = STS  
STUD = STS

DWG  
7836-32D

SCALE	N/A	CODE IDENT. #
DATE	06/14/95	03007

MATERIAL  
SEE NOTE

FINISH  
SEE NOTE

DR. BY RAG CK. BY RK

**GUDEN**  
DELIVERING HARDWARE EXCELLENCE

B	DESCRIPTION	DATE	APPD
B	VARIOUS CHANGES	10/14/02	CD
A	CHANGED STUD MATERIAL	10/18/00	CD
LTR	REVISION		

FAX: 1-631-737-2933  
EMAIL: info@guden.com  
WEB: www.guden.com

99 RAYNOR AVE.  
RONKONKOMA, N.Y. 11779  
1-800-3-HINGES