

A
SIZE

PROJECTIONS



TOLERANCES UNLESS OTHERWISE SPECIFIED:

PLACES	INCH
.XX	± .030
.XXX	± .015
.XXXX	± .005
ANGLE	3°

NOTE:

ACCEPTABLE BURR ± 10% OF MATERIAL THICKNESS
ALL TOLERANCES ARE NON-CUMULATIVE
ALL DIMENSIONS APPLY TO PART BEFORE ANY
FINISH IS APPLIED

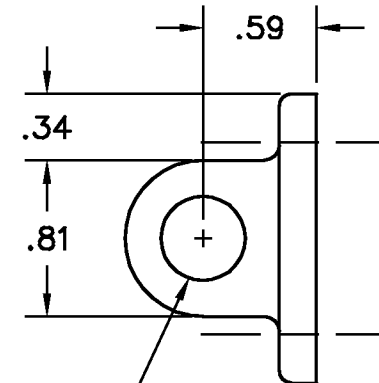
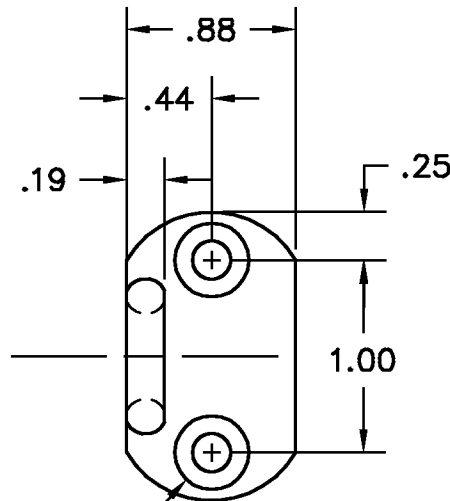

CTSK FOR 10-32 OVAL HEAD
MACHINE SCREW (2) PLACES

.438 DIA HOLE

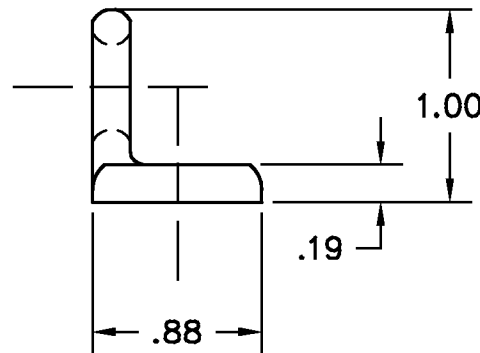

NOTES:
1. FINISH: 78- SATIN NICKEL

DWG		SCALE	1:1	CODE IDENT. #
8234-15		DATE	11/16/99	03007
MATERIAL	FINISH			
BRASS	SEE NOTE			
DR. BY RAG	CK. BY CD	99 RAYNOR AVE. RONKONKOMA, N.Y. 11779 1-800-3-HINGES		
FAX: 1-631-737-2933				
EMAIL: info@guden.com				
WEB: www.guden.com				

LTR	DESCRIPTION	DATE	APPD
	REVISION		