

A
SIZE

PROJECTIONS



TOLERANCES UNLESS OTHERWISE SPECIFIED:

PLACES	INCH
.XX	± .030
.XXX	± .015
.XXXX	± .005
ANGLE	3°

NOTE:
ACCEPTABLE BURR ± 10% OF MATERIAL THICKNESS
ALL TOLERANCES ARE NON-CUMULATIVE
ALL DIMENSIONS APPLY TO PART BEFORE ANY
FINISH IS APPLIED

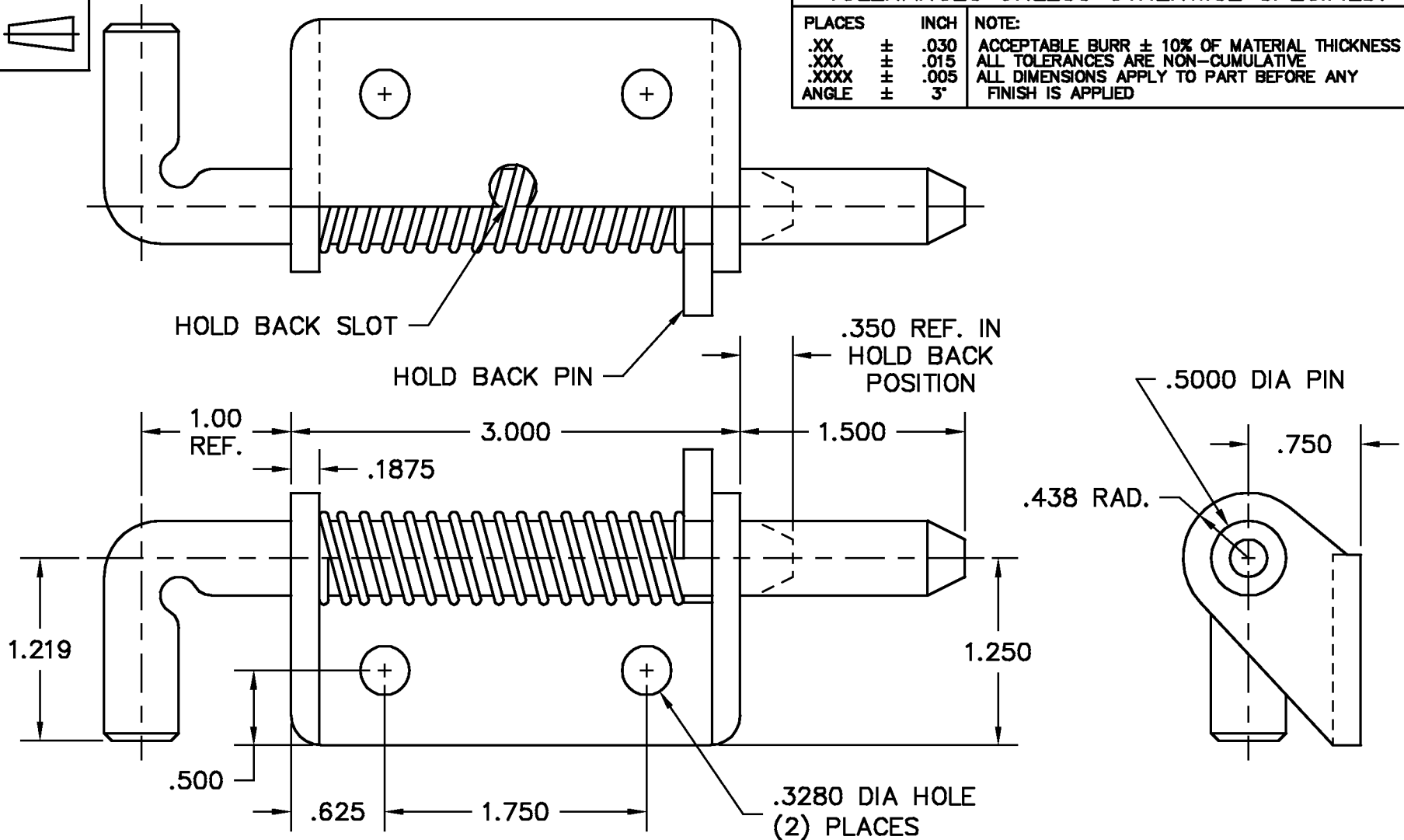

- NOTES:
1. FINISH: 90- BARREL ZINC & CLEAR CHROMATE
2. THRU HOLE (2 PL) TO BE // WITHIN .020 OF BOTTOM. REF. .750 DIM.

DWG
9297RH-02-HB

SCALE	1:1	CODE IDENT. #
DATE	05/27/03	03007

MATERIAL PS	FINISH SEE NOTE
DR. BY RAG	CK. BY CD



LTR	DESCRIPTION	DATE	APPD
	REVISION		

FAX: 1-631-737-2933
EMAIL: info@guden.com
WEB: www.guden.com

99 RAYNOR AVE.
RONKONKOMA, N.Y. 11779
1-800-3-HINGES