

A
SIZE

PROJECTIONS



TOLERANCES UNLESS OTHERWISE SPECIFIED:

PLACES	INCH
.XX	± .030
.XXX	± .015
.XXXX	± .005
ANGLE	± 3°

NOTE:

ACCEPTABLE BURR ± 10% OF MATERIAL THICKNESS
ALL TOLERANCES ARE NON-CUMULATIVE
ALL DIMENSIONS APPLY TO PART BEFORE ANY FINISH IS APPLIED

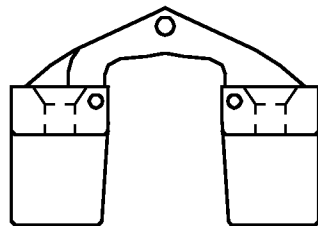
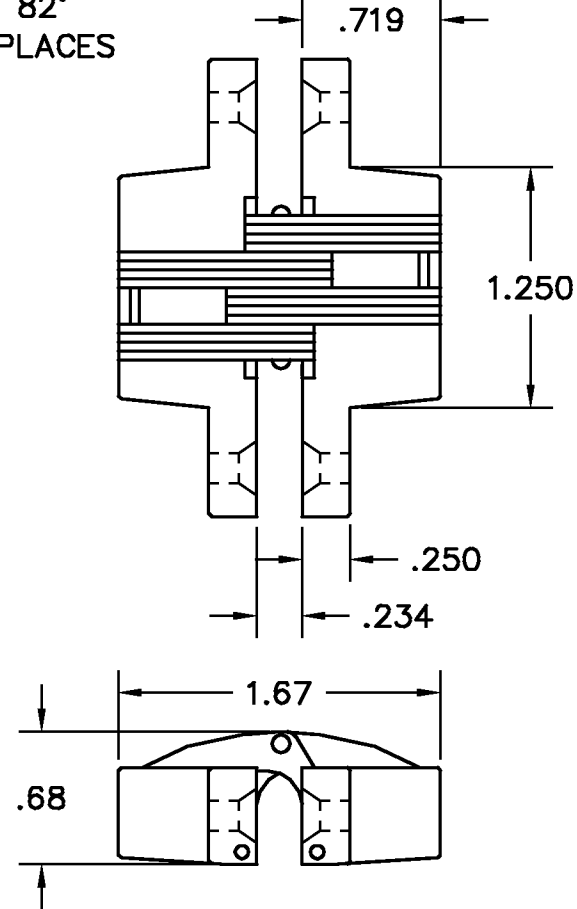
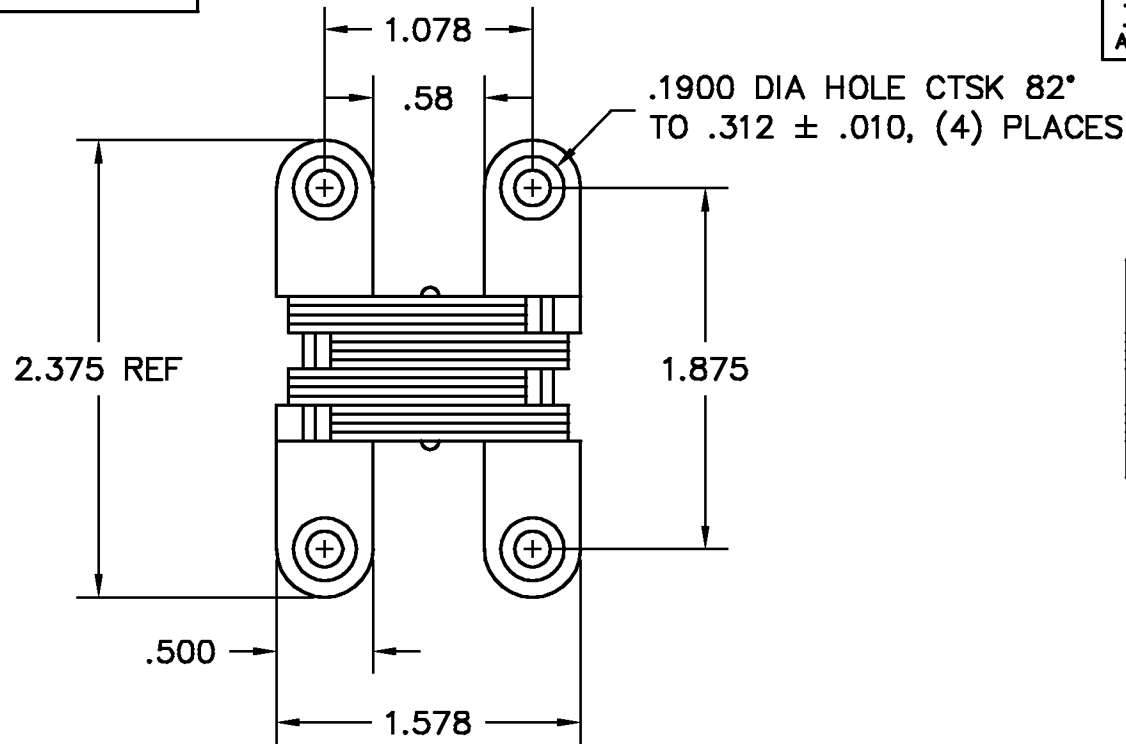

NOTES:

1. FINISH: 30- BARREL BRASS & BRITE BURNISH
2. MATERIAL: LINKS & PINS = PS
BODY = ZINC DIE CAST

DWG

205-04

SCALE	1:1	CODE IDENT. #
DATE	02/15/02	03007

MATERIAL SEE NOTE
FINISH SEE NOTE

DR. BY RAG CK. BY CD



A	ADDED DIMS	05/10/02	CD
LTR	DESCRIPTION	DATE	APPD
	REVISION		

FAX: 1-631-737-2933
EMAIL: info@guden.com
WEB: www.guden.com

99 RAYNOR AVE.
RONKONKOMA, N.Y. 11779
1-800-3-HINGES