

A  
SIZE

PROJECTIONS



TOLERANCES UNLESS OTHERWISE SPECIFIED:

PLACES	INCH
.XX	± .030
.XXX	± .015
.XXXX	± .005
ANGLE	3°

NOTE:  
ACCEPTABLE BURR ± 10% OF MATERIAL THICKNESS  
ALL TOLERANCES ARE NON-CUMULATIVE  
ALL DIMENSIONS APPLY TO PART BEFORE ANY  
FINISH IS APPLIED

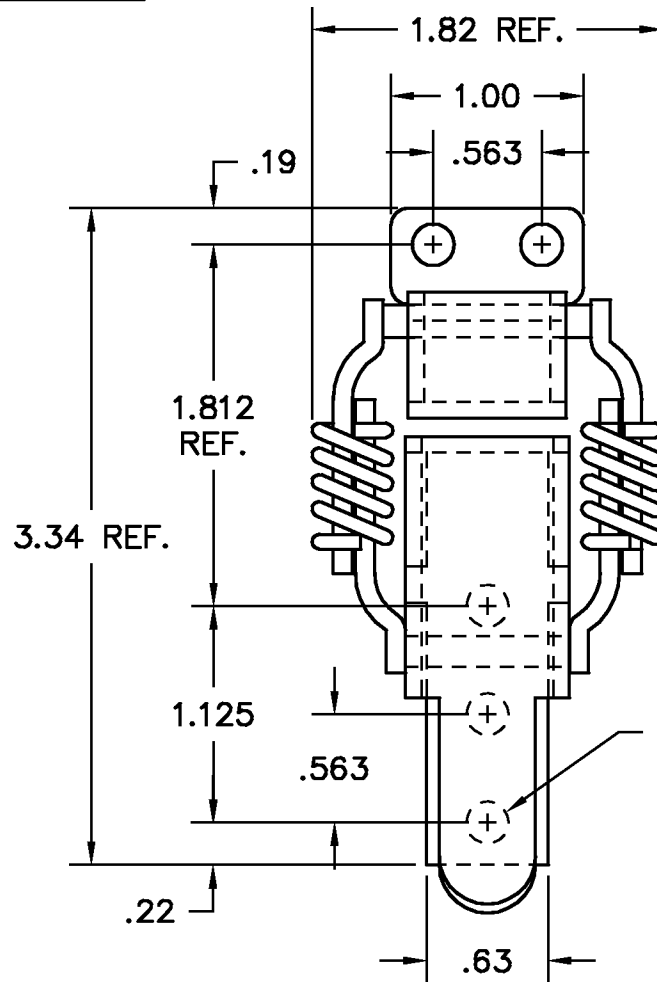

.0830 THICK  
MAT'L

.2180 DIA HOLE  
(5) PLACES

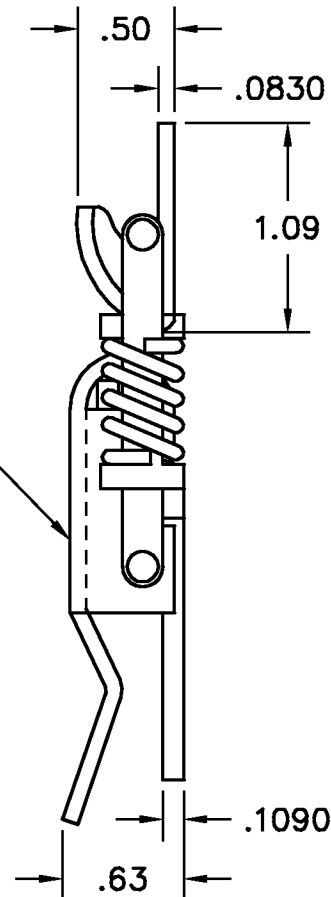

NOTES:  
1. FINISH: 90- BARREL ZINC & CLEAR CHROMATE

DWG

8342-02

SCALE	1:1	CODE IDENT. #
DATE	08/04/00	03007

MATERIAL	FINISH
PS	SEE NOTE

DR. BY RAG CK. BY CD

**GUDEN**  
DELIVERING HARDWARE EXCELLENCE

LTR	DESCRIPTION	DATE	APPD
	REVISION		

FAX: 1-631-737-2933  
EMAIL: info@guden.com  
WEB: www.guden.com

99 RAYNOR AVE.  
RONKONKOMA, N.Y. 11779  
1-800-3-HINGES