

A
SIZE

PROJECTIONS



TOLERANCES UNLESS OTHERWISE SPECIFIED:

PLACES	INCH
.XX	± .030
.XXX	± .015
.XXXX	± .005
ANGLE	3°

NOTE:
ACCEPTABLE BURR ± 10% OF MATERIAL THICKNESS
ALL TOLERANCES ARE NON-CUMULATIVE
ALL DIMENSIONS APPLY TO PART BEFORE ANY FINISH IS APPLIED

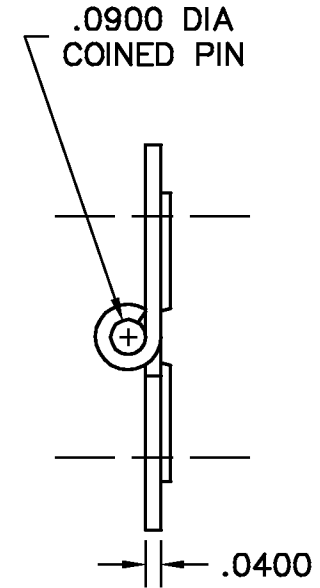
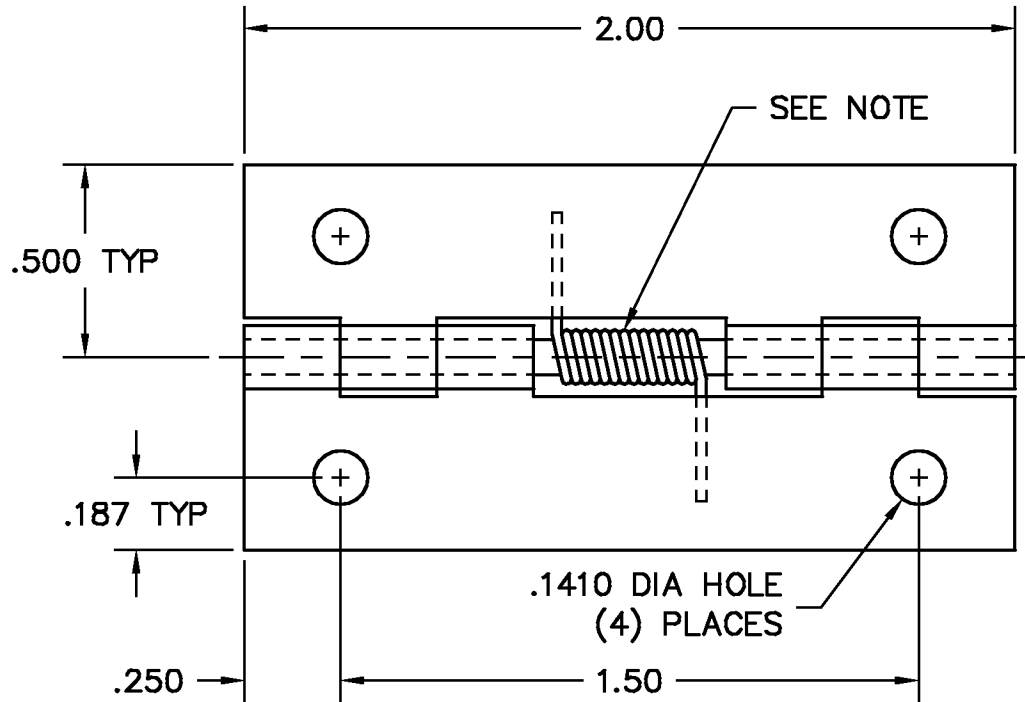

NOTES:

1. FINISH: 90- BARREL ZINC & CLEAR CHROMATE
2. SPRING: SPR-014 LOADED TO CLOSE, (1) PLACE
3. MATERIAL: LEAVES = PS
PIN = BRASS

DWG		SCALE	2:1	CODE IDENT. #
1644-02		DATE	09/12/02	03007
MATERIAL	FINISH			
SEE NOTE	SEE NOTE			
DR. BY RAG	CK. BY CD	99 RAYNOR AVE. RONKONKOMA, N.Y. 11779 1-800-3-HINGES		
FAX: 1-631-737-2933				
EMAIL: info@guden.com				
WEB: www.guden.com				

LTR	DESCRIPTION	DATE	APPD
	REVISION		