

A
SIZE

PROJECTIONS



TOLERANCES UNLESS OTHERWISE SPECIFIED:

PLACES	INCH
.XX	± .030
.XXX	± .015
.XXXX	± .005
ANGLE	3°

NOTE:
ACCEPTABLE BURR ± 10% OF MATERIAL THICKNESS
ALL TOLERANCES ARE NON-CUMULATIVE
ALL DIMENSIONS APPLY TO PART BEFORE ANY FINISH IS APPLIED

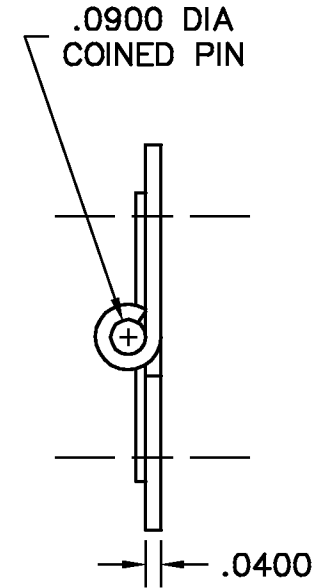
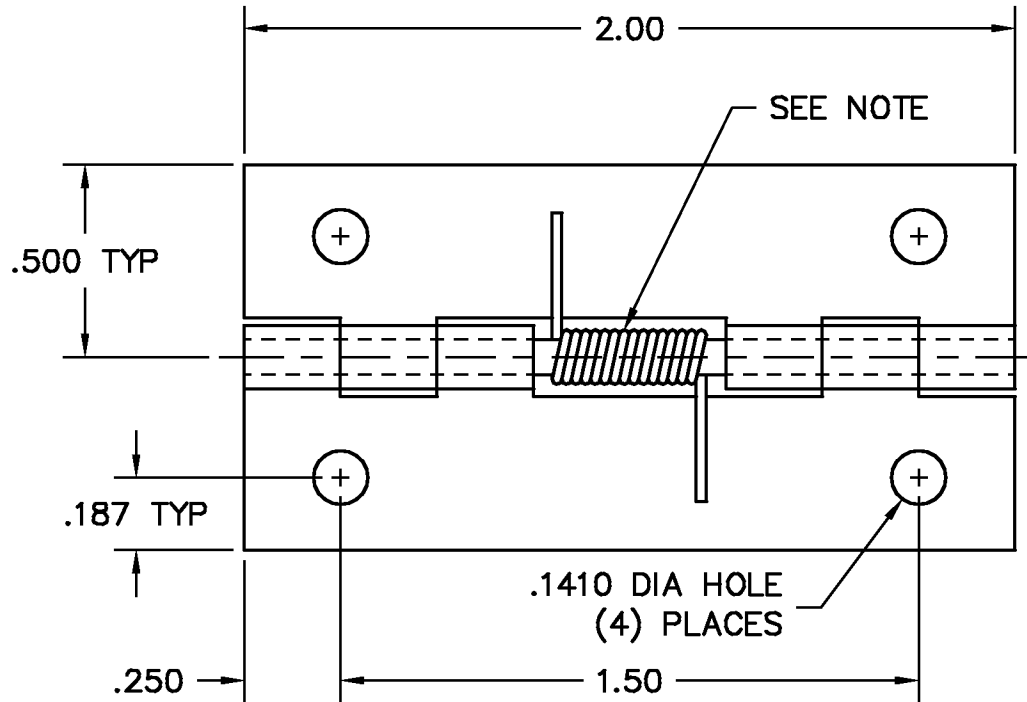

NOTES:

1. FINISH: 90- BARREL ZINC & CLEAR CHROMATE
2. SPRING: SPR-007 LOADED TO OPEN, (1) PLACE
3. MATERIAL: LEAVES = PS
PIN = BRASS

DWG		SCALE	2:1	CODE IDENT. #
1643-02		DATE	04/28/99	03007
MATERIAL	FINISH			
SEE NOTE	SEE NOTE			
DR. BY RAG	CK. BY CD	99 RAYNOR AVE. RONKONKOMA, N.Y. 11779 1-800-3-HINGES		
FAX: 1-631-737-2933 EMAIL: info@guden.com WEB: www.guden.com				
REVISION				

C	CORRECTED SPRING	07/17/02	CD
B	CHANGED MATERIAL THICK	09/08/99	CD
A	REDRAWN	04/28/99	CD
LTR	DESCRIPTION	DATE	APPD
REVISION			