

A
SIZE

PROJECTIONS



TOLERANCES UNLESS OTHERWISE SPECIFIED:

PLACES	INCH
.XX	± .030
.XXX	± .015
.XXXX	± .005
ANGLE	3°

NOTE:
ACCEPTABLE BURR ± 10% OF MATERIAL THICKNESS
ALL TOLERANCES ARE NON-CUMULATIVE
ALL DIMENSIONS APPLY TO PART BEFORE ANY FINISH IS APPLIED

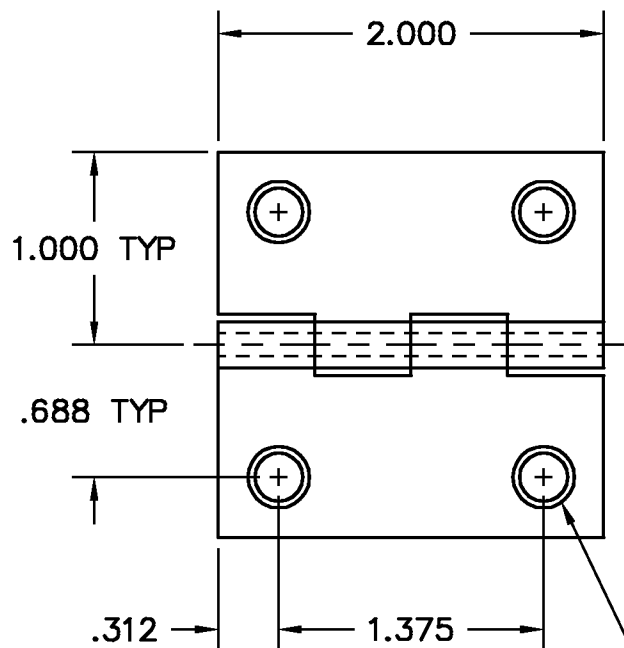

.1250 DIA PIN
STAKED IN PLACE

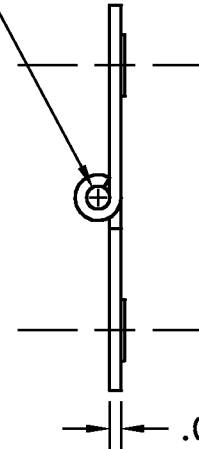

THE SLIGHTLY RAISED AREA ON THE BACK OF THESE HINGES MAKE THEM ACCEPTABLE FOR USE ON WOOD ONLY. THEY WILL NOT LAY FLAT ON FIBERGLASS OR METAL SURFACES.

.250 DIA HOLE PUNCH CTSK 82° TO .320 ± .010, (4) PLACES

NOTES:
1. FINISH: 21- ELECTRO POLISH

DWG		SCALE	1:1	CODE IDENT. #
SP0992		DATE	06/20/01	03007
MATERIAL	FINISH			
STS	SEE NOTE			
DR. BY RAG	CK. BY CD	99 RAYNOR AVE. RONKONKOMA, N.Y. 11779 1-800-3-HINGES		
FAX: 1-631-737-2933				
EMAIL: info@guden.com				
WEB: www.guden.com				

A	DESCRIPTION	DATE	APPD
	ADDED "WOOD ONLY" NOTE	07/24/01	CD
LTR	REVISION		