

**A**  
SIZE

PROJECTIONS



TOLERANCES UNLESS OTHERWISE SPECIFIED:

PLACES	INCH
.XX	± .030
.XXX	± .015
.XXXX	± .005
ANGLE	± 3°

NOTE:  
ACCEPTABLE BURR ± 10% OF MATERIAL THICKNESS  
ALL TOLERANCES ARE NON-CUMULATIVE  
ALL DIMENSIONS APPLY TO PART BEFORE ANY FINISH IS APPLIED

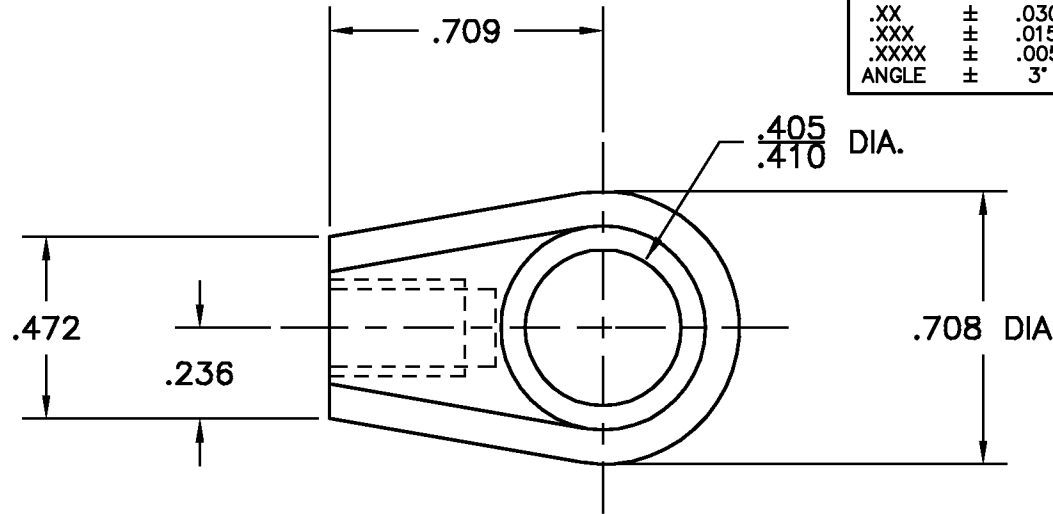

M6 X 1.0-6H THREAD  
FULL THREAD .350 MIN DEPTH

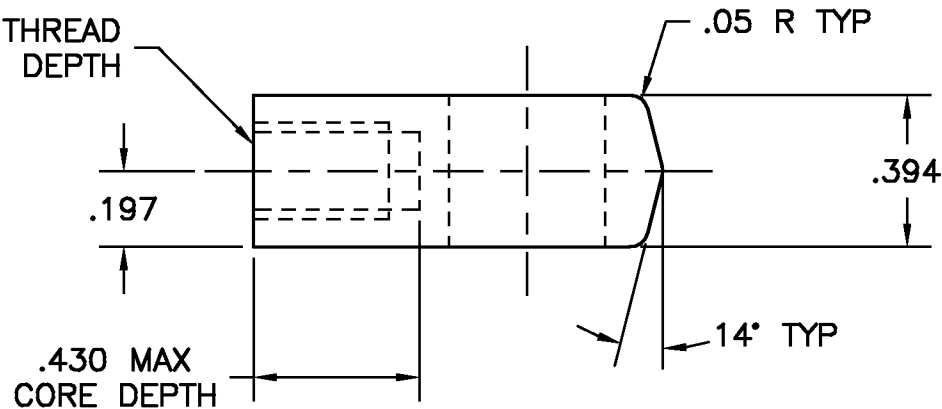

NOTES:

1. FINISH: 00- NO FINISH
2. MATERIAL: ZINC DIECAST

DWG		SCALE	2:1	CODE IDENT. #
EF201		DATE	01/29/99	03007
MATERIAL	FINISH			
SEE NOTE	SEE NOTE			
DR. BY RAG	CK. BY CD	<p>99 RAYNOR AVE. RONKONKOMA, N.Y. 11779 1-800-3-HINGES</p>		
FAX: 1-631-737-2933				
EMAIL: info@guden.com				
WEB: www.guden.com				

B	DESCRIPTION	DATE	APPD
B	CORRECTED THREAD	02/23/10	DW
A	CHANGED THREAD	04/05/99	CD
LTR	REVISION		