

A
SIZE

PROJECTIONS



TOLERANCES UNLESS OTHERWISE SPECIFIED:

PLACES	INCH	NOTE:
.XX	± .030	ACCEPTABLE BURR ± 10% OF MATERIAL THICKNESS ALL TOLERANCES ARE NON-CUMULATIVE ALL DIMENSIONS APPLY TO PART BEFORE ANY FINISH IS APPLIED
.XXX	± .015	
.XXXX	± .005	
ANGLE	3°	

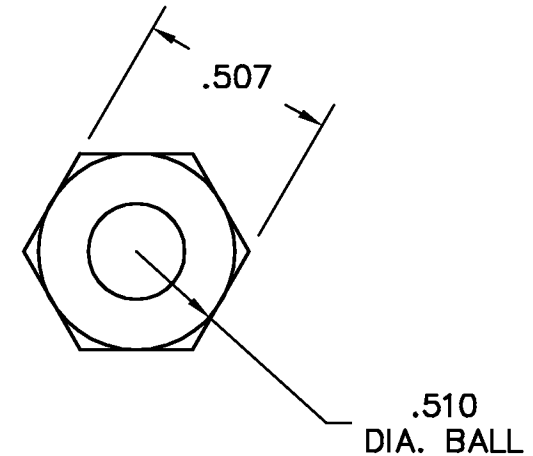
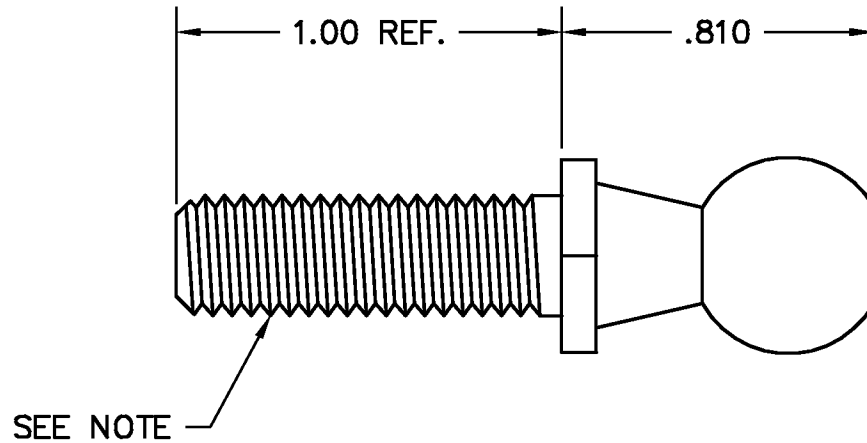

NOTES:

1. FINISH: 90- BARREL ZINC & CLEAR CHROMATE
2. THREADED FOR 5/16-18 UNC-2A
3. CASE HARDEN AND TEMPER TO ROCKWELL C-32 MIN., .004-.008 DEEP AND CHECK ON SPHERICAL DIAMETER.
4. AVAILABLE FOR USE WITH GUDEN END FITTING EF100

DWG		SCALE	2:1	CODE IDENT. #
BS106-02		DATE	08/24/04	03007
MATERIAL	FINISH			
PS	SEE NOTE			
DR. BY RAG	CK. BY CD	<p>99 RAYNOR AVE. RONKONKOMA, N.Y. 11779 1-800-3-HINGES</p>		
<p>FAX: 1-631-737-2933 EMAIL: info@guden.com WEB: www.guden.com</p>				

A	.810 WAS .735	09/29/04	CD
LTR	DESCRIPTION	DATE	APPD
	REVISION		