

A
SIZE

PROJECTIONS



TOLERANCES UNLESS OTHERWISE SPECIFIED:

PLACES	INCH
.XX	± .030
.XXX	± .015
.XXXX	± .005
ANGLE	3°

NOTE:
ACCEPTABLE BURR ± 10% OF MATERIAL THICKNESS
ALL TOLERANCES ARE NON-CUMULATIVE
ALL DIMENSIONS APPLY TO PART BEFORE ANY FINISH IS APPLIED

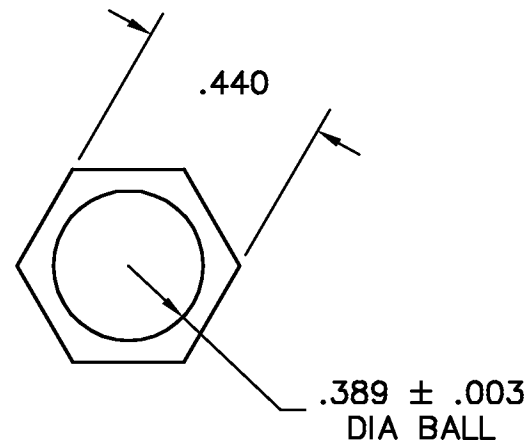
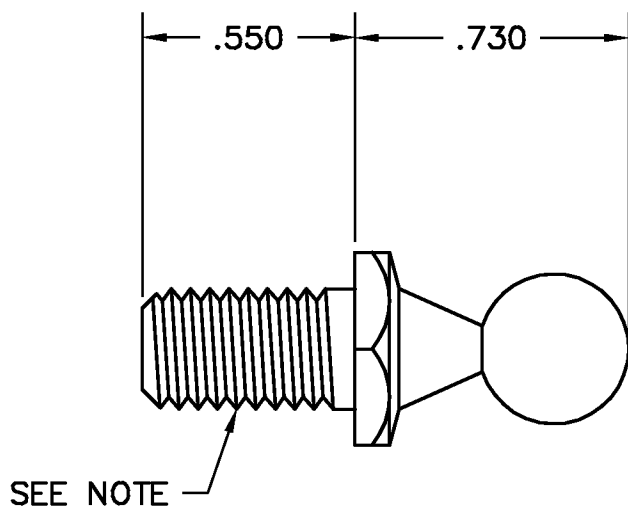

- NOTES:
1. FINISH: 97- BARREL ZINC & YELLOW CHROMATE
 2. THREADED FOR M8 X 1.25
 3. CASE HARDEN AND TEMPER TO ROCKWELL C-45 MIN., .004-.008 DEEP AND CHECK ON SPHERICAL DIAMETER.
 4. AVAILABLE FOR USE WITH GUDEN END FITTINGS EF030, EF090 AND EF110.

DWG		SCALE	2:1	CODE IDENT. #
BS105-02		DATE	05/24/05	03007
MATERIAL	FINISH			
PS	SEE NOTE			
DR. BY RAG	CK. BY CD	99 RAYNOR AVE. RONKONKOMA, N.Y. 11779 1-800-3-HINGES		
FAX: 1-631-737-2933				
EMAIL: info@guden.com				
WEB: www.guden.com				

B	DESCRIPTION	DATE	APPD
	BALL SHAPE	05/19/10	JG
	BALL SHAPE & FINISH	08/08/05	CD
LTR	REVISION		