

A
SIZE

PROJECTIONS



TOLERANCES UNLESS OTHERWISE SPECIFIED:

PLACES	INCH
.XX	± .030
.XXX	± .015
.XXXX	± .005
ANGLE	3°

NOTE:
ACCEPTABLE BURR ± 10% OF MATERIAL THICKNESS
ALL TOLERANCES ARE NON-CUMULATIVE
ALL DIMENSIONS APPLY TO PART BEFORE ANY FINISH IS APPLIED

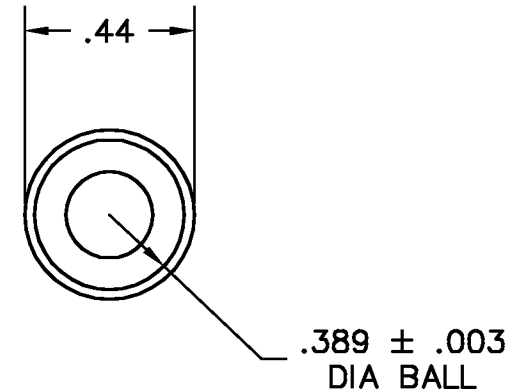
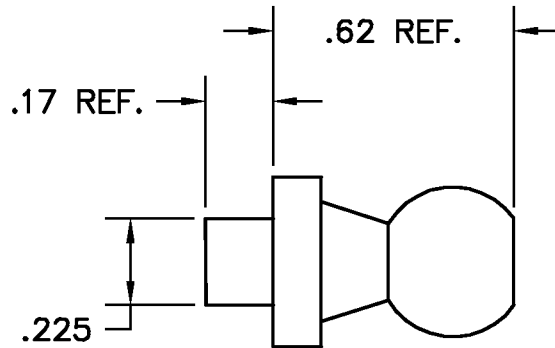

NOTES:

1. FINISH: 90- BARREL ZINC & CLEAR CHROMATE
2. BLANK STUD FOR RIVETING
3. CASE HARDEN AND TEMPER TO ROCKWELL C-45 MIN., .004-.008 DEEP AND CHECK ON SPHERICAL DIAMETER.
4. AVAILABLE FOR USE WITH GUDEN END FITTINGS EF030, EF090 AND EF110.

DWG		SCALE	2:1	CODE IDENT. #
BS103-02		DATE	08/26/04	03007
MATERIAL	FINISH			
PS	SEE NOTE			
DR. BY RAG	CK. BY CD	99 RAYNOR AVE. RONKONKOMA, N.Y. 11779 1-800-3-HINGES		
FAX: 1-631-737-2933				
EMAIL: info@guden.com				
WEB: www.guden.com				

A	.225 WAS .250	11/09/06	CD
LTR	DESCRIPTION	DATE	APPD
	REVISION		