

**A**  
SIZE

PROJECTIONS



TOLERANCES UNLESS OTHERWISE SPECIFIED:

PLACES	INCH	NOTE:
.XX	± .030	ACCEPTABLE BURR ± 10% OF MATERIAL THICKNESS ALL TOLERANCES ARE NON-CUMULATIVE ALL DIMENSIONS APPLY TO PART BEFORE ANY FINISH IS APPLIED
.XXX	± .015	
.XXXX	± .005	
ANGLE	3°	

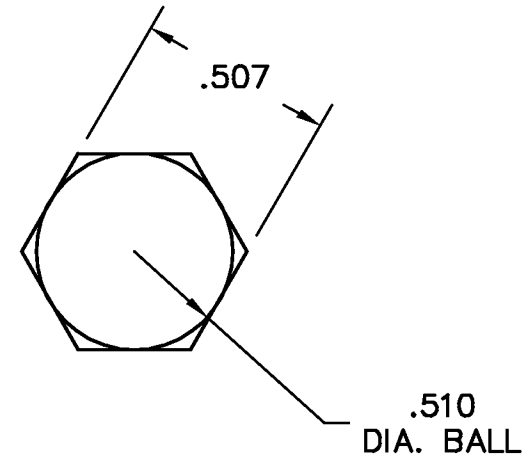
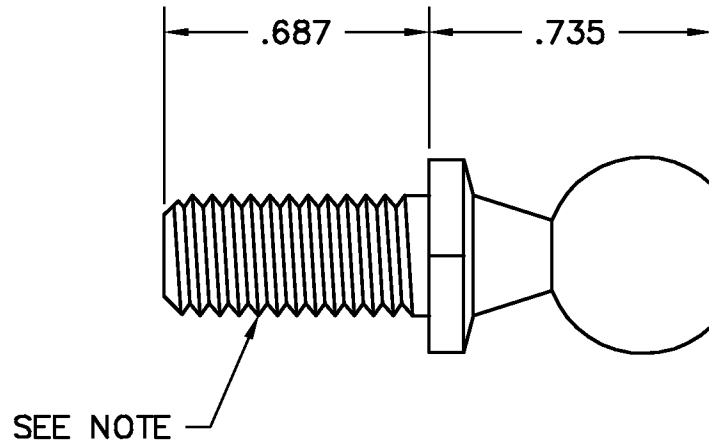

NOTES:

1. FINISH: 90- BARREL ZINC & CLEAR CHROMATE
2. THREADED FOR 5/16-18 UNC-2A
3. CASE HARDEN AND TEMPER TO ROCKWELL C-32 MIN., .004-.008 DEEP AND CHECK ON SPHERICAL DIAMETER.
4. AVAILABLE FOR USE WITH GUDEN END FITTING EF100

G	CHANGED ROCKWELL	05/21/04	CD	DWG	SCALE	2:1	CODE IDENT. #		
F	VARIOUS CHANGES	04/30/04	CD		BS102-02	DATE	02/01/99	03007	
E	REDRAWN, VARIOUS CHANGES	02/01/99	CD	MATERIAL					
D	CHANGED DIMS	01/02/92	AG	PS				FINISH	SEE NOTE
C	ADDED NOTE 3	09/11/90	AG	DR. BY RAG				CK. BY CD	
B	ENTIRE SHAFT NOW THREADED	01/04/90	AG	FAX: 1-631-737-2933 EMAIL: info@guden.com WEB: www.guden.com					
LTR	DESCRIPTION	DATE	APPD			99 RAYNOR AVE. RONKONKOMA, N.Y. 11779 1-800-3-HINGES			
REVISION									