

A
SIZE

PROJECTIONS

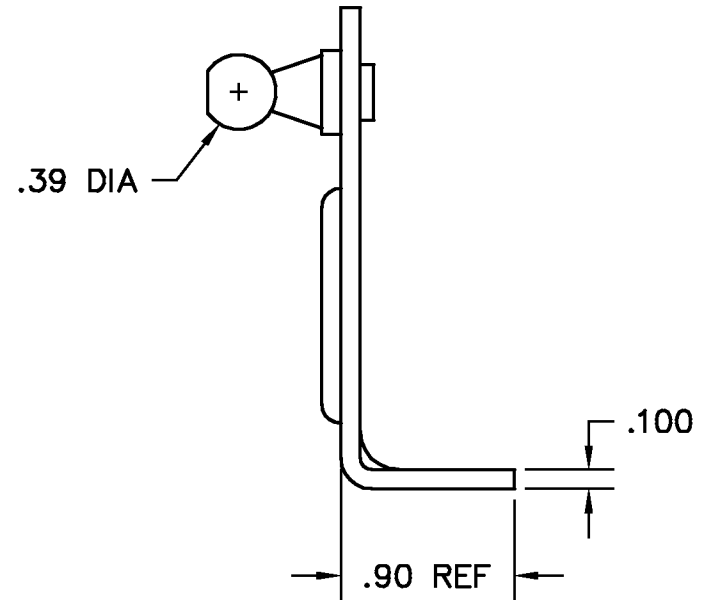

.200 DIA HOLE
(3) PLACES

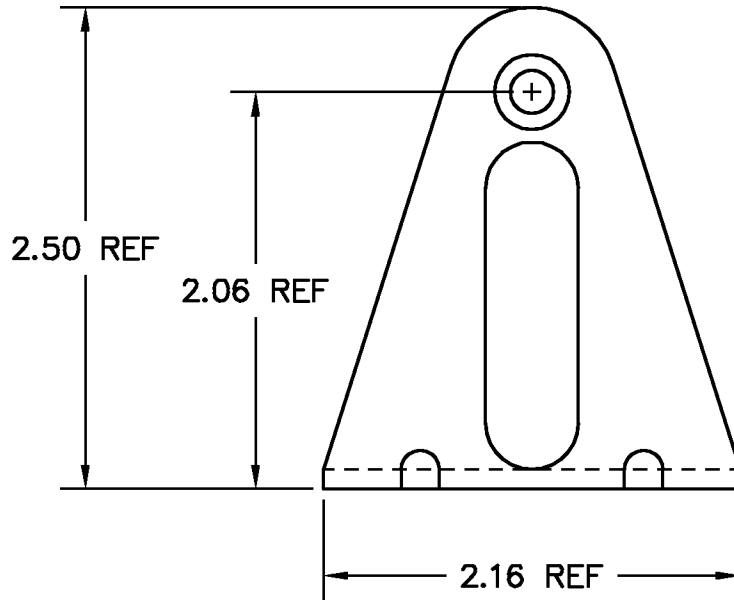
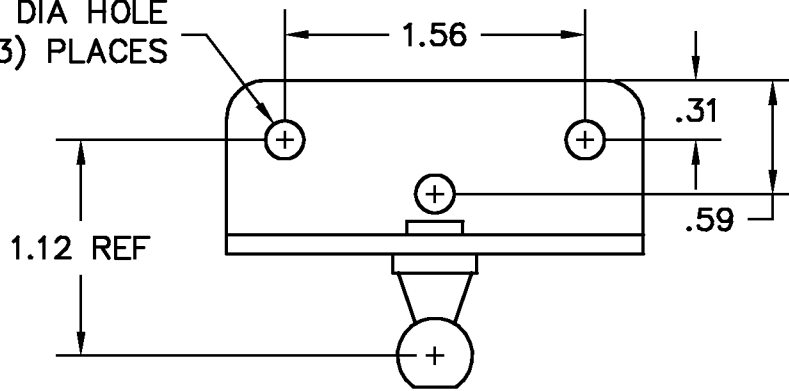

TOLERANCES UNLESS OTHERWISE SPECIFIED:

PLACES	INCH	NOTE:
.XX	± .030	ACCEPTABLE BURR ± 10% OF MATERIAL THICKNESS ALL TOLERANCES ARE NON-CUMULATIVE ALL DIMENSIONS APPLY TO PART BEFORE ANY FINISH IS APPLIED
.XXX	± .015	
.XXXX	± .005	
ANGLE	3°	

NOTES:

1. FINISH: 12- POLISH - ALL SURFACES
2. AVAILABLE FOR USE WITH GUDEN P/N's EF030, EF090 AND EF110 END FITTINGS

LTR	DESCRIPTION	DATE	APPD
D	CHANGED HOLE LOCATIONS	10/05/07	CD
C	ALL STS, POLISH	02/05/04	CD
B	.47 WAS .53	07/29/02	CD
A	ADDED FINISH	06/20/00	CD
REVISION			

DWG BR201-32	
MATERIAL STS	FINISH SEE NOTE
DR. BY RAG	CK. BY CD
FAX: 1-631-737-2933 EMAIL: info@guden.com WEB: www.guden.com	

SCALE	1:1	CODE IDENT. #
DATE	07/18/96	03007
 DELIVERING HARDWARE EXCELLENCE		
99 RAYNOR AVE. RONKONKOMA, N.Y. 11779 1-800-3-HINGES		