

A
SIZE

PROJECTIONS



TOLERANCES UNLESS OTHERWISE SPECIFIED:

PLACES	INCH
.XX	± .030
.XXX	± .015
.XXXX	± .005
ANGLE	3°

NOTE:
ACCEPTABLE BURR ± 10% OF MATERIAL THICKNESS
ALL TOLERANCES ARE NON-CUMULATIVE
ALL DIMENSIONS APPLY TO PART BEFORE ANY
FINISH IS APPLIED

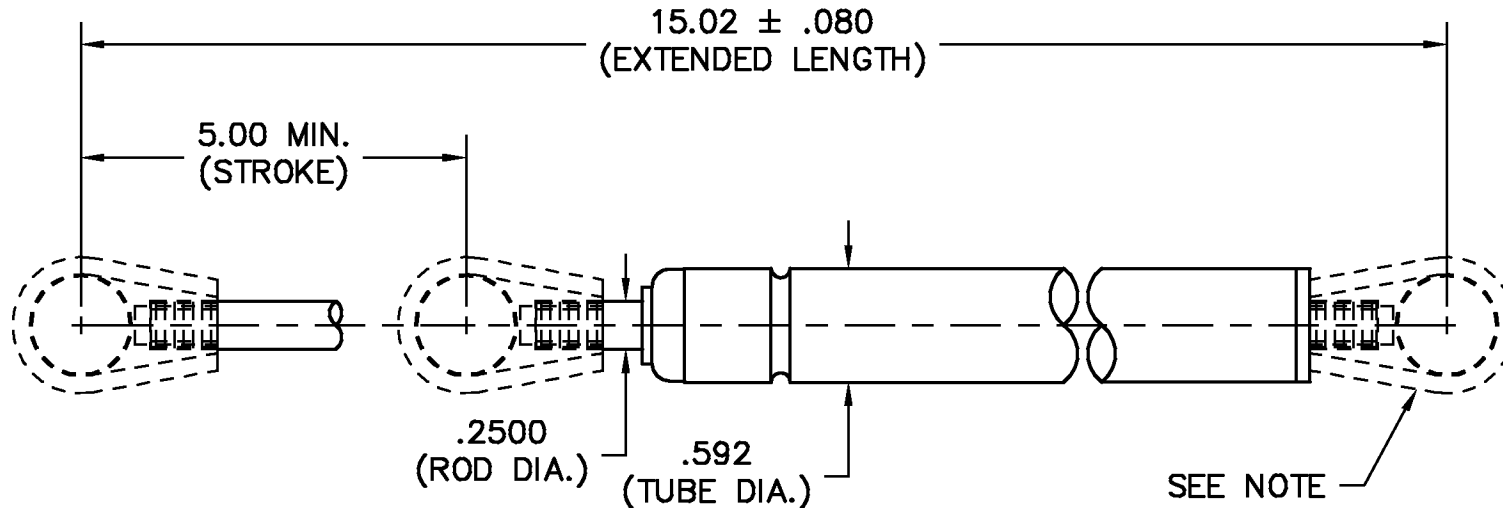

NOTES:

1. FINISH: 61- BLACK PAINT (TUBE) & CHROME (ROD)
2. LABEL TO BE STAMPED WITH CORRESPONDING GUDEN P/N AND DATE CODE (DATE CODE EX.: 0589 IS THE 58th DAY OF 1999)
3. MEDIUM DAMPING (ORIFICE PLATE D) IN COMPRESSION
4. EXTENDED LENGTH IS MEASURED FROM END FITTING MOUNTING POINTS FOR FAT BLADE, I AND K END FITTINGS.

DWG		SCALE	1:1	CODE IDENT. #
GDC53-D		DATE	12/27/99	03007
MATERIAL	FINISH			
PS	SEE NOTE			
DR. BY RAG	CK. BY CD	<p>99 RAYNOR AVE. RONKONKOMA, N.Y. 11779 1-800-3-HINGES</p>		
FAX: 1-631-737-2933				
EMAIL: info@guden.com WEB: www.guden.com				

A	CHANGED NOTE 4	06/06/06	CD
LTR	DESCRIPTION	DATE	APPD
	REVISION		