

A  
SIZE

PROJECTIONS



TOLERANCES UNLESS OTHERWISE SPECIFIED:

PLACES	INCH
.XX	± .030
.XXX	± .015
.XXXX	± .005
ANGLE	3°

NOTE:  
ACCEPTABLE BURR ± 10% OF MATERIAL THICKNESS  
ALL TOLERANCES ARE NON-CUMULATIVE  
ALL DIMENSIONS APPLY TO PART BEFORE ANY FINISH IS APPLIED

.187 DIA PIN  
SPUN BOTH ENDS

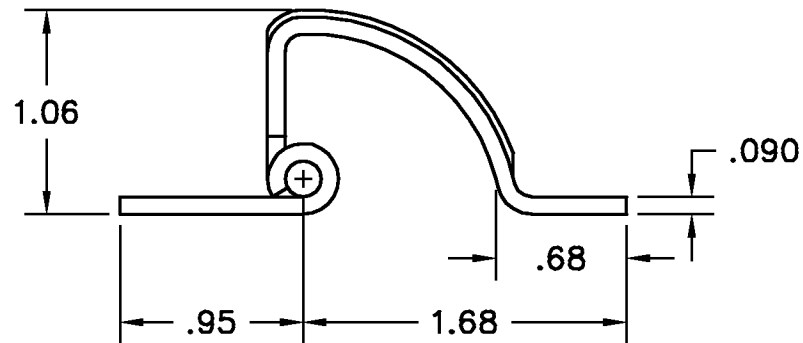
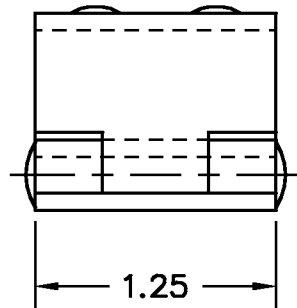
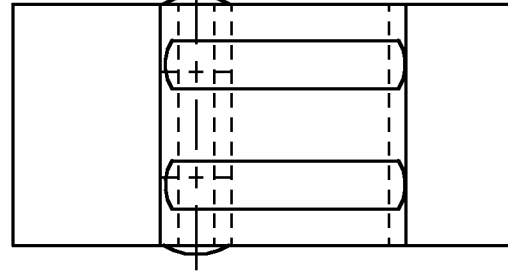

NOTES:

1. FINISH: 00- NO FINISH

LTR	DESCRIPTION	DATE	APPD
D	1.06 WAS 1.09	09/19/01	CD
C	REDRAWN	01/05/99	CD
B	REDRAWN, VARIOUS CHANGES	02/22/94	CD
A	1.06 WAS 1.01, 1.25 WAS 1.29	10/26/90	AG
REVISION			

DWG NHSS9291	
MATERIAL STS	FINISH SEE NOTE
DR. BY RAG	CK. BY CD
FAX: 1-631-737-2933 EMAIL: info@guden.com WEB: www.guden.com	

SCALE	1:1	CODE IDENT. #
DATE	01/05/99	03007
99 RAYNOR AVE. RONKONKOMA, N.Y. 11779 1-800-3-HINGES		