

**A**  
SIZE

PROJECTIONS



TOLERANCES UNLESS OTHERWISE SPECIFIED:

PLACES	INCH	NOTE:
.XX	± .030	ACCEPTABLE BURR ± 10% OF MATERIAL THICKNESS ALL TOLERANCES ARE NON-CUMULATIVE ALL DIMENSIONS APPLY TO PART BEFORE ANY FINISH IS APPLIED
.XXX	± .015	
.XXXX	± .005	
ANGLE	3°	

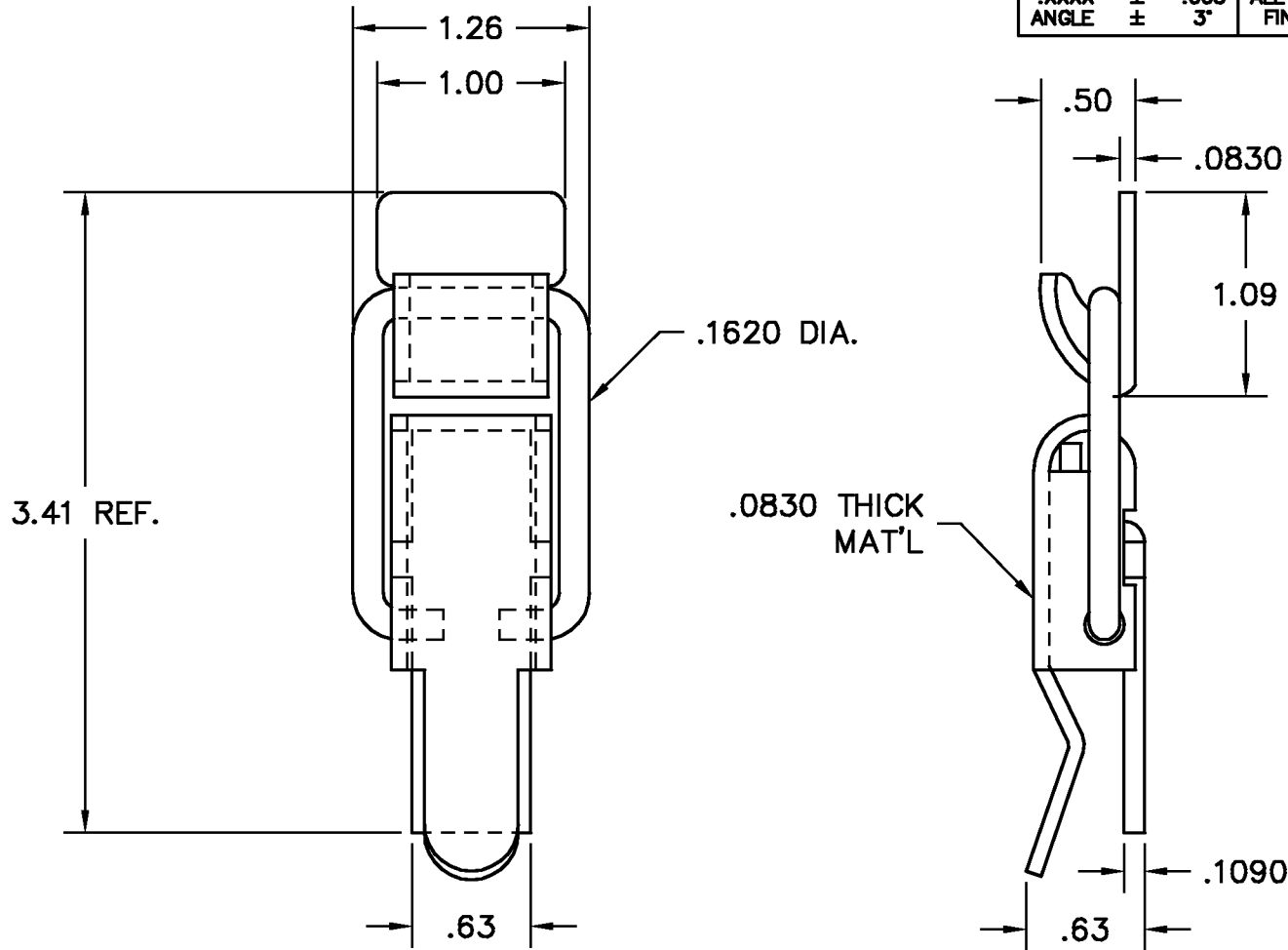

NOTES:  
1. FINISH: 00- NO FINISH

DWG		SCALE	1:1	CODE IDENT. #
NHPS8333		DATE	06/22/98	03007
MATERIAL	FINISH			
PS	SEE NOTE			
DR. BY RAG	CK. BY CD	99 RAYNOR AVE. RONKONKOMA, N.Y. 11779 1-800-3-HINGES		
FAX: 1-631-737-2933				
EMAIL: info@guden.com				
WEB: www.guden.com				

B	DESCRIPTION	DATE	APPD
B	CORRECTED MATERIAL	08/20/98	CD
A	REDRAWN, VARIOUS CHANGES	06/22/98	CD
LTR	REVISION		