

A
SIZE

PROJECTIONS



.260 DIA HOLE CTSK 82°
TO .390 (2) PLACES, BOTH SIDES

.213 DIA HOLE CTSK 82°
TO .372 (2) PLACES

TOLERANCES UNLESS OTHERWISE SPECIFIED:

PLACES	INCH	NOTE:
.XX	± .030	ACCEPTABLE BURR ± 10% OF MATERIAL THICKNESS ALL TOLERANCES ARE NON-CUMULATIVE ALL DIMENSIONS APPLY TO PART BEFORE ANY FINISH IS APPLIED
.XXX	± .015	
.XXXX	± .005	
ANGLE	± 3°	

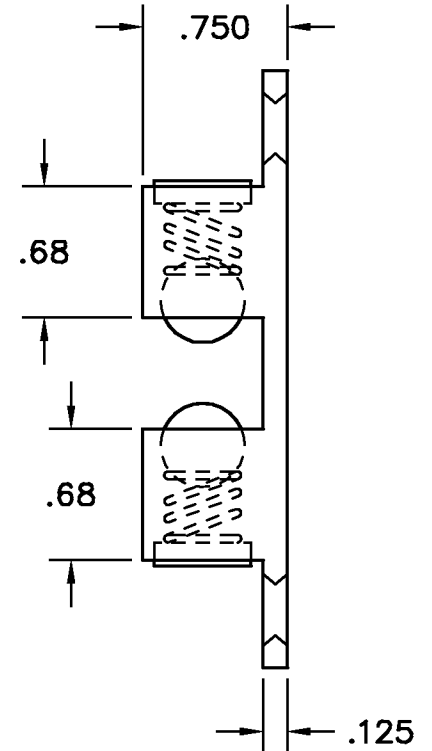
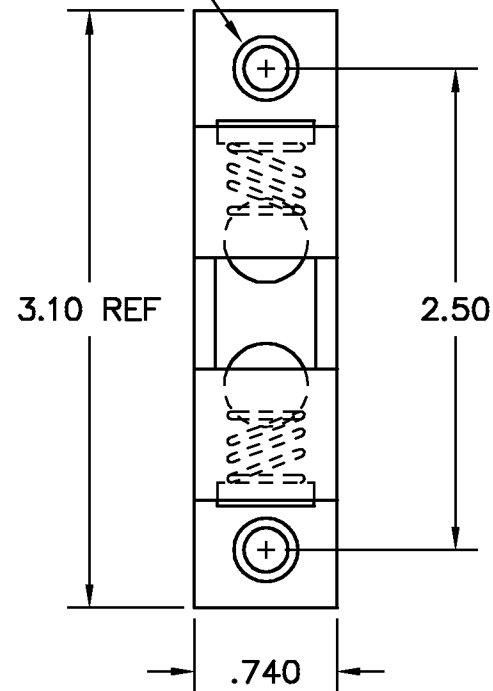
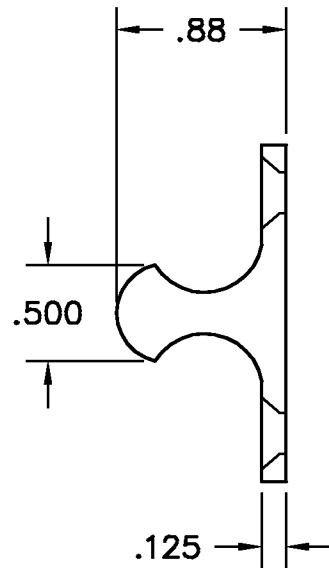
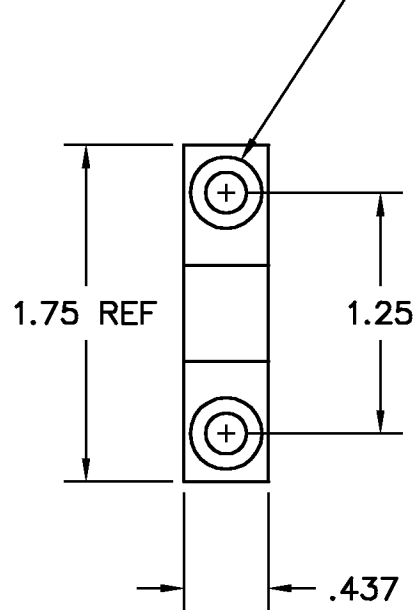

- NOTES:
 1. FINISH: 46A DULL CHROME (BRUSHED)
 2. MATERIAL: BODY, STRIKE, AND
 ADJUSTER SCREW = BRASS
 SPRING = STS
 BALL = GRADE 1000
 NAVAL BRONZE

LTR	DESCRIPTION	DATE	APPD
F	HOLE & CTSK	10/08/08	CD
E	CHANGED FINISH	02/07/02	CD
D	VARIOUS CHANGES	07/24/01	CD
C	CHANGED SPRING	04/18/01	CD
B	CHANGED SPRING	05/02/00	CD
A	CHANGED SPRING	02/14/00	CD
REVISION			

DWG		SCALE	1:1	CODE IDENT. #
3-26D		DATE	06/16/98	03007
MATERIAL	FINISH			
SEE NOTE	SEE NOTE			
DR. BY RAG	CK. BY CD			
FAX: 1-631-737-2933		99 RAYNOR AVE. RONKONKOMA, N.Y. 11779 1-800-3-HINGES		
EMAIL: info@guden.com				
WEB: www.guden.com				