

A  
SIZE

PROJECTIONS



TOLERANCES UNLESS OTHERWISE SPECIFIED:

PLACES	INCH
.XX	± .030
.XXX	± .015
.XXXX	± .005
ANGLE	3°

NOTE:  
ACCEPTABLE BURR ± 10% OF MATERIAL THICKNESS  
ALL TOLERANCES ARE NON-CUMULATIVE  
ALL DIMENSIONS APPLY TO PART BEFORE ANY FINISH IS APPLIED

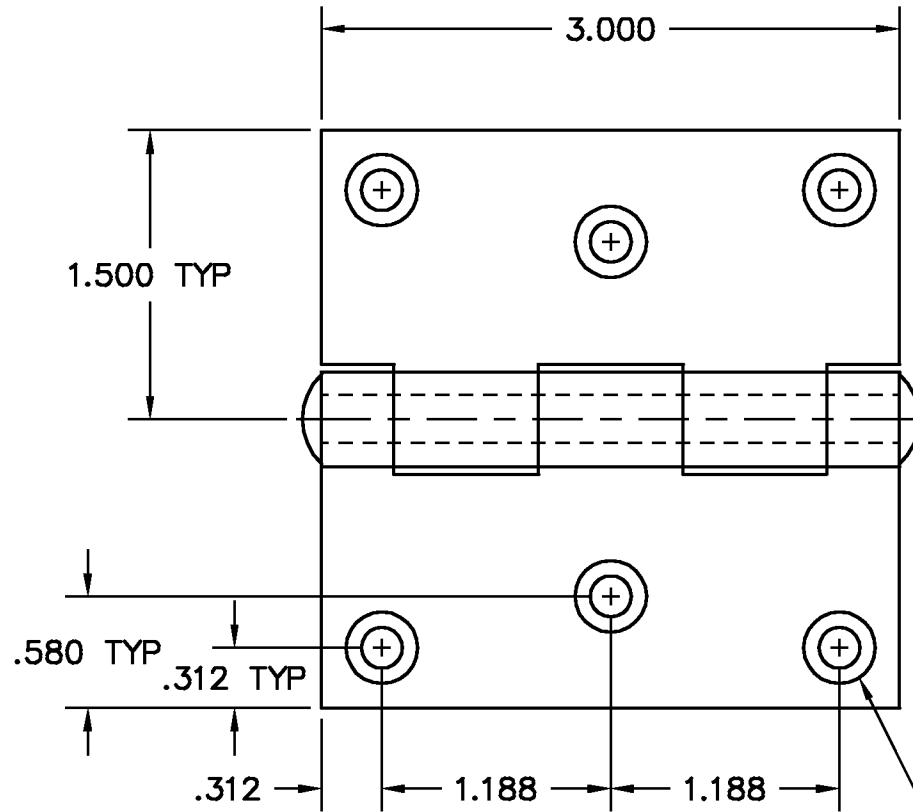

.2500 DIA PIN  
SPUN BOTH ENDS

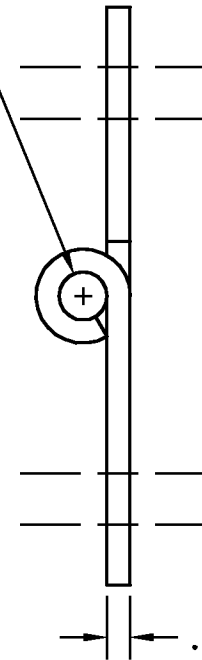

.2130 DIA HOLE CTSK 82°  
TO .372 ± .010, (6) PLACES

NOTES:

1. FINISH: 00- NO FINISH
2. KNUCKLE CONFIGURATION MAY VARY FROM PRINT

D	MATERIAL THICKNESS	05/03/07	CD
C	MATERIAL THICK, NOTE 2	10/28/05	CD
B	REDRAWN	12/23/98	CD
A	REDRAWN	03/19/86	CD
LTR	DESCRIPTION	DATE	APPD
REVISION			

DWG	
8000301225	
MATERIAL	FINISH
STS	SEE NOTE
DR. BY RAG	CK. BY CD
FAX: 1-631-737-2933	
EMAIL: info@guden.com	
WEB: www.guden.com	

SCALE	1:1	CODE IDENT. #
DATE	12/23/98	03007
 DELIVERING HARDWARE EXCELLENCE		
99 RAYNOR AVE. RONKONKOMA, N.Y. 11779 1-800-3-HINGES		