

A  
SIZE

PROJECTIONS



.2500 DIA HOLE CTSK 82°  
TO .372 ± .010 (6) PLACES

TOLERANCES UNLESS OTHERWISE SPECIFIED:

PLACES	INCH
.XX	± .030
.XXX	± .015
.XXXX	± .005
ANGLE	± 3°

NOTE:

ACCEPTABLE BURR ± 10% OF MATERIAL THICKNESS  
ALL TOLERANCES ARE NON-CUMULATIVE  
ALL DIMENSIONS APPLY TO PART BEFORE ANY  
FINISH IS APPLIED

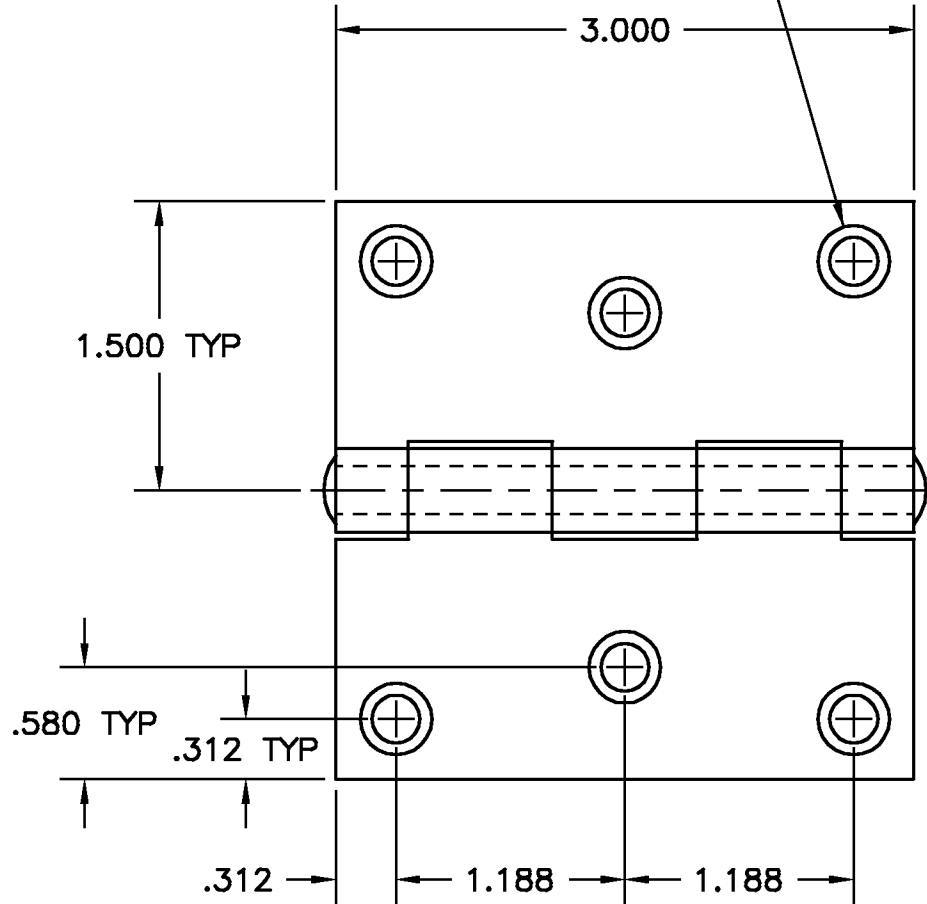

.2500 DIA PIN  
SPUN BOTH ENDS

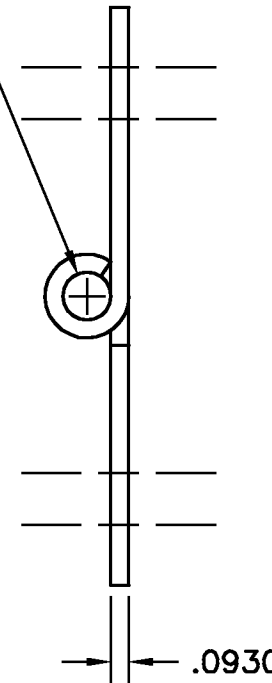

NOTES:

1. FINISH: 00- NO FINISH
2. KNUCKLE CONFIGURATION MAY VARY FROM PRINT

DWG

8000300925

SCALE 1:1 CODE IDENT. #

DATE 12/23/98 03007

D	CORRECTED # OF HOLES	09/17/07	CD
C	MATERIAL THICK, NOTE 2	10/28/05	CD
B	REDRAWN	12/23/98	CD
LTR	DESCRIPTION	DATE	APPD
REVISION			

MATERIAL STS	FINISH SEE NOTE
DR. BY RAG	CK. BY CD

FAX: 1-631-737-2933  
EMAIL: info@guden.com  
WEB: www.guden.com

**GUDEN**  
DELIVERING HARDWARE EXCELLENCE

99 RAYNOR AVE.  
RONKONKOMA, N.Y. 11779  
1-800-3-HINGES