

A  
SIZE

PROJECTIONS



TOLERANCES UNLESS OTHERWISE SPECIFIED:

PLACES	INCH
.XX	± .030
.XXX	± .015
.XXXX	± .005
ANGLE	3°

NOTE:  
 ACCEPTABLE BURR ± 10% OF MATERIAL THICKNESS  
 ALL TOLERANCES ARE NON-CUMULATIVE  
 ALL DIMENSIONS APPLY TO PART BEFORE ANY  
 FINISH IS APPLIED

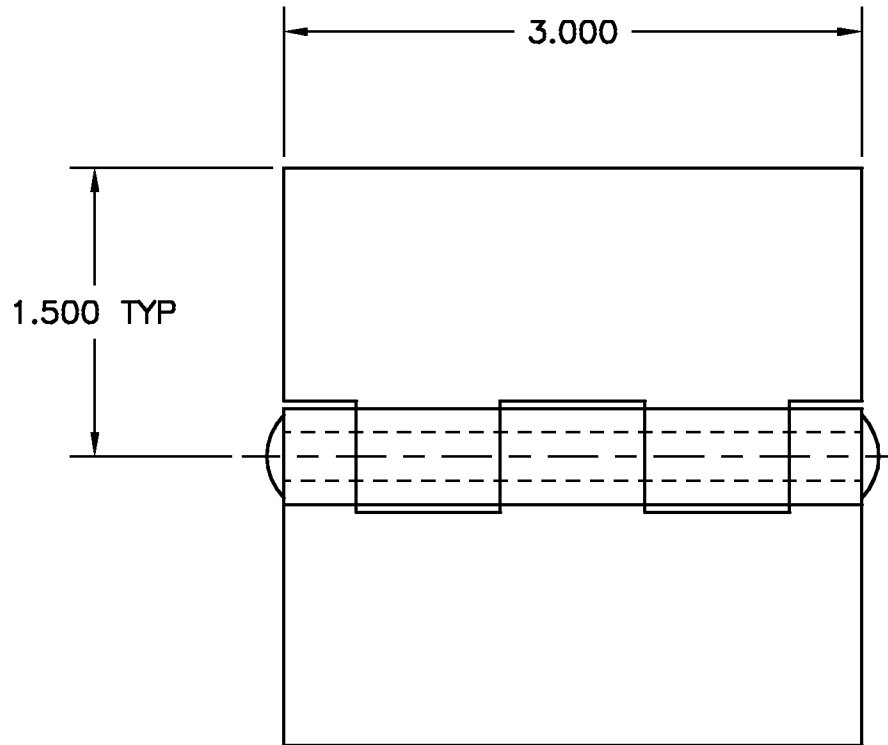

.2500 DIA PIN  
 SPUN BOTH ENDS

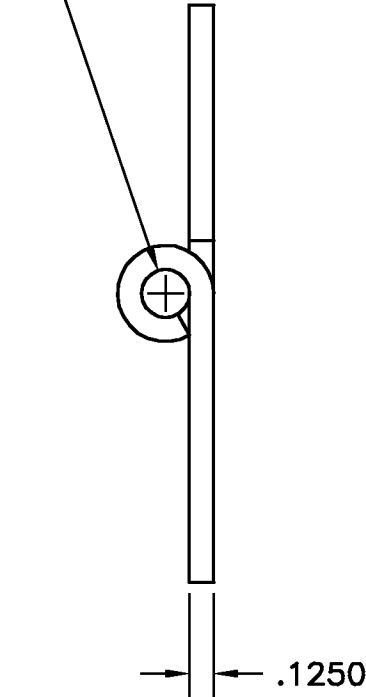

NOTES:  
 1. FINISH: 00- NO FINISH

DWG 6000301225		SCALE 1:1	CODE IDENT. # 03007
MATERIAL PS		FINISH SEE NOTE	
DR. BY RAG		CK. BY CD	
FAX: 1-631-737-2933 EMAIL: info@guden.com WEB: www.guden.com		 99 RAYNOR AVE. RONKONKOMA, N.Y. 11779 1-800-3-HINGES	

LTR	DESCRIPTION	DATE	APPD
	REVISION		